

January 18, 2002

Dear Blue Bird Owner:

This notice is sent to you in accordance with the requirements of the National Traffic and Motor Vehicle Safety Act.

Blue Bird Body Company has determined that a defect, which relates to motor vehicle safety exists in certain 1999 through 2002 model year Blue Bird All American and TC/2000 school and transit buses and Q-Bus and Commercial Series transit buses. Blue Bird is conducting a recall to correct this defect.

The defect involves inconsistent torque on the Hendrickson rear air suspension hanger fasteners and the rear axle torque rod fasteners. Subject buses must be modified according to the attached instructions.

Blue Bird Body Company's evaluation of the risk to motor vehicle safety reasonably related to this defect is movement between rear axle/suspension components results in unexpected rear axle movement affecting steering control of the bus.

Your Blue Bird bus (es) affected by recall R01FL are identified by body serial number(s) on the enclosed reply sheets. If you no longer own the subject bus (es), please complete the appropriate section of the pink reply sheet and return to Blue Bird in the enclosed pink postage prepaid envelope.

You may perform this modification yourself or have the work done by a qualified repair facility convenient to you. You may contact your Blue Bird distributor for assistance.

Time required to perform recall R01FL is dependent upon modifications performed.

Replace 5/8 " rear air suspension hanger fasteners with class L9-fastener system-----3.00hrs
Replace torque rod fasteners-----1.00hr
If torque rod spring seat studs are broken, replace individual spring seat -----1.00hr

Page 2

Upon completion of the recall the owner should complete and return the pink reply sheet in the completing the appropriate section of the pink reply sheet. If repair is performed by other than the owner or a Blue Bird distributor, attach a copy of the paid work order/invoice to the reply

Important: Your prompt return of the pink reimbursement sheet, complete with the correct Body Serial Numbers, permits Blue Bird to update the record indicating recall has been completed and this may have caused.

If Blue Bird Body Company should fail to or is unable to remedy this condition without charge

**ADMINISTRATOR
NATIONAL HIGHWAY TRAFFIC SAFETY ADMINISTRATION**

or you may call The National Highway Traffic Safety Administration toll free at:

1-888-327-4236

Thank you,

Bill Coleman

BLUE BIRD BODY COMPANY

RECALL R01FL INSTRUCTIONS
FASTENER REPLACEMENT ON HENDRICKSON REAR AIR RIDE SUSPENSION

NOTES:

1. Park vehicle on level surface and remove ignition key.
2. Chock front wheels.
3. Support rear axle with jack stands.
4. Support both frame rails with jack stands immediately before or behind suspension.
5. Deflate air bags.
6. Read and Follow ALL of Blue Bird and Hendrickson Instructions, cautions and warnings.
7. **HENDRICKSON TECH PUB** refers to HENDRICKSON Technical publication for H.A.S. Suspension. HENDRICKSON PUBLICATION No. 17730-212, Dated January 1999, REVISION C. A copy is enclosed.

TORQUE ARM FASTENER REPLACEMENT INSTRUCTIONS

1. On the left side Hendrickson rear air suspension, remove the torque rod fasteners (Items 1, 2, and 3) that attach the torque rod to the frame hanger assembly. See drawing on page 2. Note: If a torque rod shim(s) has been installed, note location, remove and keep. Remove the lock nuts (Item 1) and flat washers (Items 2) that attach the torque rod to the spring seat. Remove and keep torque rod. Discard all fasteners.
2. A kit will be supplied containing the required fasteners for both sides of the suspension. The kit contains twelve (12) 5/8" hardened flat washers, four 5/8"-11 UNC Hex Head bolts 4.5" long, eight 5/8"-11 UNC lock nuts, and four 5/8" studs.
3. Remove and discard the two 5/8" studs (Items 4) in the spring seat bracket and install two new studs by following the instructions on page 11 in **Hendrickson Tech Pub** under **SPRING SEATS** in the **Component Replacement Section**.

NOTE: If either stud is broken and cannot be removed, replace existing seat with a new spring seat from Blue Bird before installing new locknuts and hardened flat washers. See "**INSTRUCTIONS FOR REPLACING SEAT**". Contact Bill Coleman at 478-822-2242 for a replacement spring seat.

4. Install torque rod onto spring seat studs. Install two new 5/8" hardened flat washers (Item 2) and two new lock nuts (Item 1) onto spring studs. Hand tighten locknuts.

5. Position torque rod against frame hanger assembly. Install two 5/8" torque rod bolts (Item 3) and two hardened flat washers (Item 2). Install two lock nuts (Item 1) and two flat washers (2) onto bolts. If a torque rod shim(s) had been removed, re-install in the same position as originally installed. Torque these bolts and the locknuts for the spring seat studs to 150-205 ft. lbs.
6. Repeat above procedure on right side of Hendrickson rear air suspension.

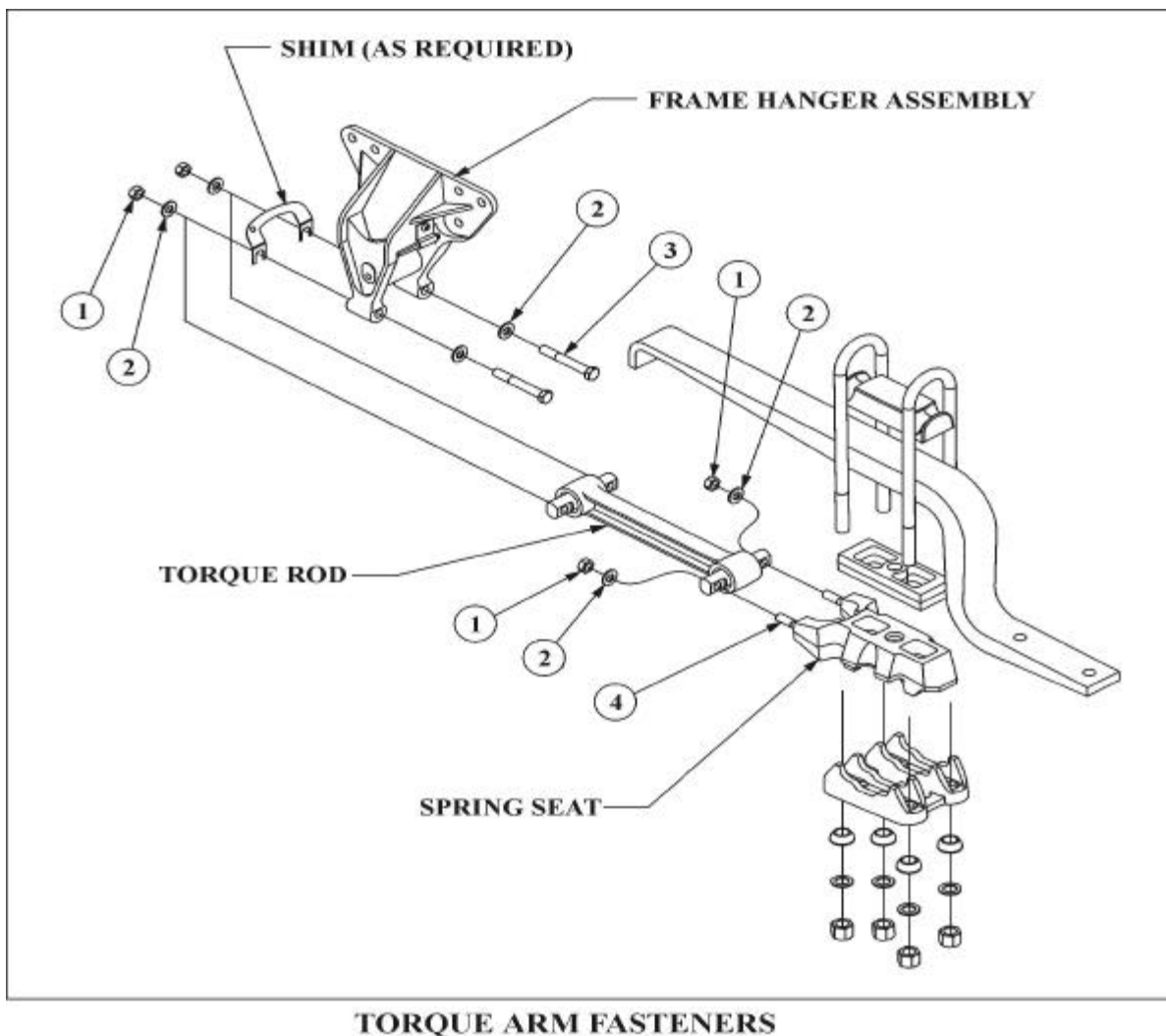

INSTRUCTIONS FOR REPLACING SPRING SEAT (IF REQUIRED)

Contact Bill Coleman at Blue Bird at 478-822-2242 for the correct spring seat (Item 1).

Note: Provide Bill Coleman with Blue Bird body number for the vehicle along with the Hendrickson part number, if legible. Hendrickson part number is painted across the spring seat. (Reference **Hendrickson Tech Pub** page 11 figure 13)

1. New u-bolts (Items 2 and 3), spherical washers (Item 4), flat washers (Item 5), and u-bolt nuts (Item 6) will be supplied with a new spring seat (Item 1). Discard all removed u-bolts, washers and nuts. **DO NOT REUSE**.
2. Follow the instructions in **Hendrickson Tech Pub** under **SPRING SEATS** in the **Component Replacement Section** page 11 for spring seat replacement and installation of new U-bolts. Torque per instructions found on the back page of **Hendrickson Tech Pub**.
3. Recommend that the drive axle alignment be checked after replacing spring seat. Rear axle alignment specifications are 0 to ¼” of center using laser alignment equipment.

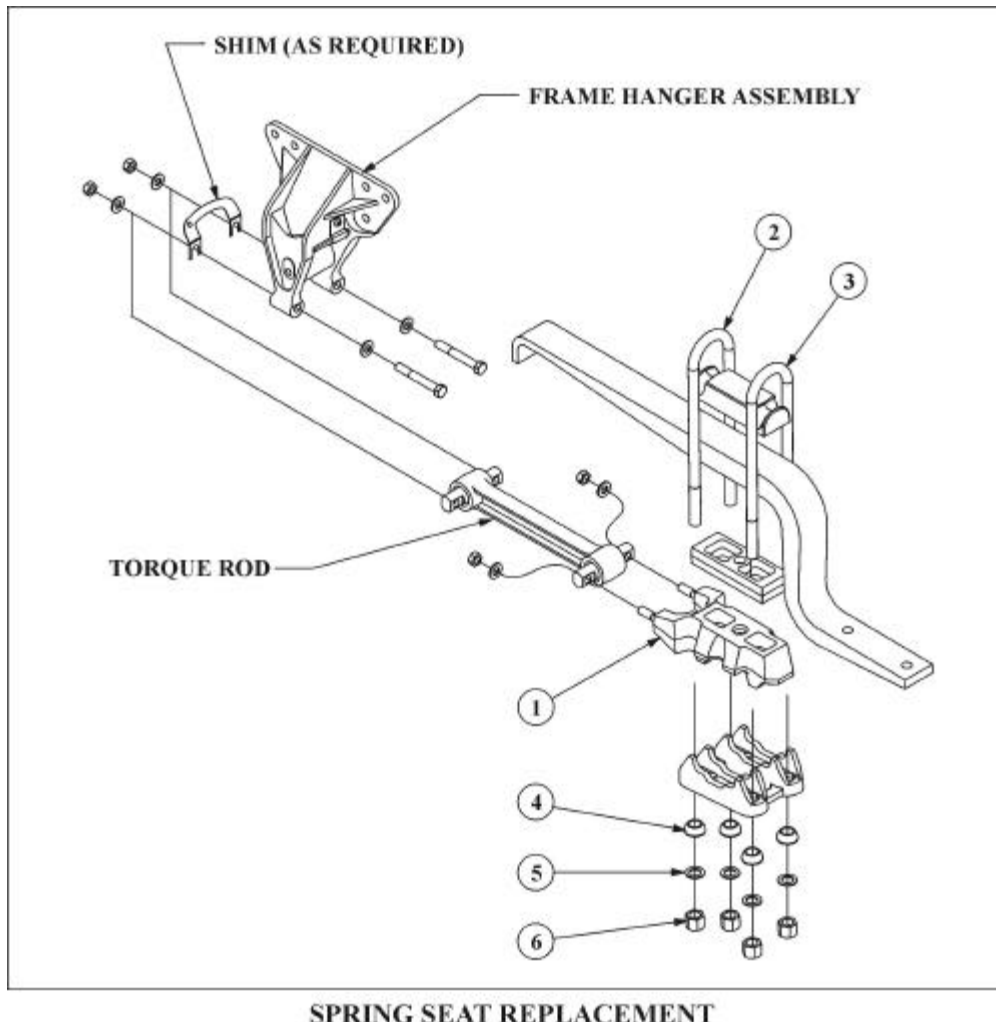

FRAME HANGER ASSEMBLY BOLT REPLACEMENT

Caution: Wires and tubing may need to be moved to reach bolt heads with socket. Take the necessary steps to protect all wiring and tubing.

1. On the rear suspension left frame hanger assembly (it is recommended to replace two bolts at the time), remove and discard the six 5/8" bolts (Item 1), twelve hardened flat washers (Item 2), and six 5/8" locknuts (Item 3) shown in the illustration. Install six new 5/8" Class L9 bolts (Item 1), twelve Class L9 washers (Item 2), and six Class L9 locknuts (Item 3). Torque (by nut) to 205-ft. lbs.
2. Repeat on right frame hanger assembly.

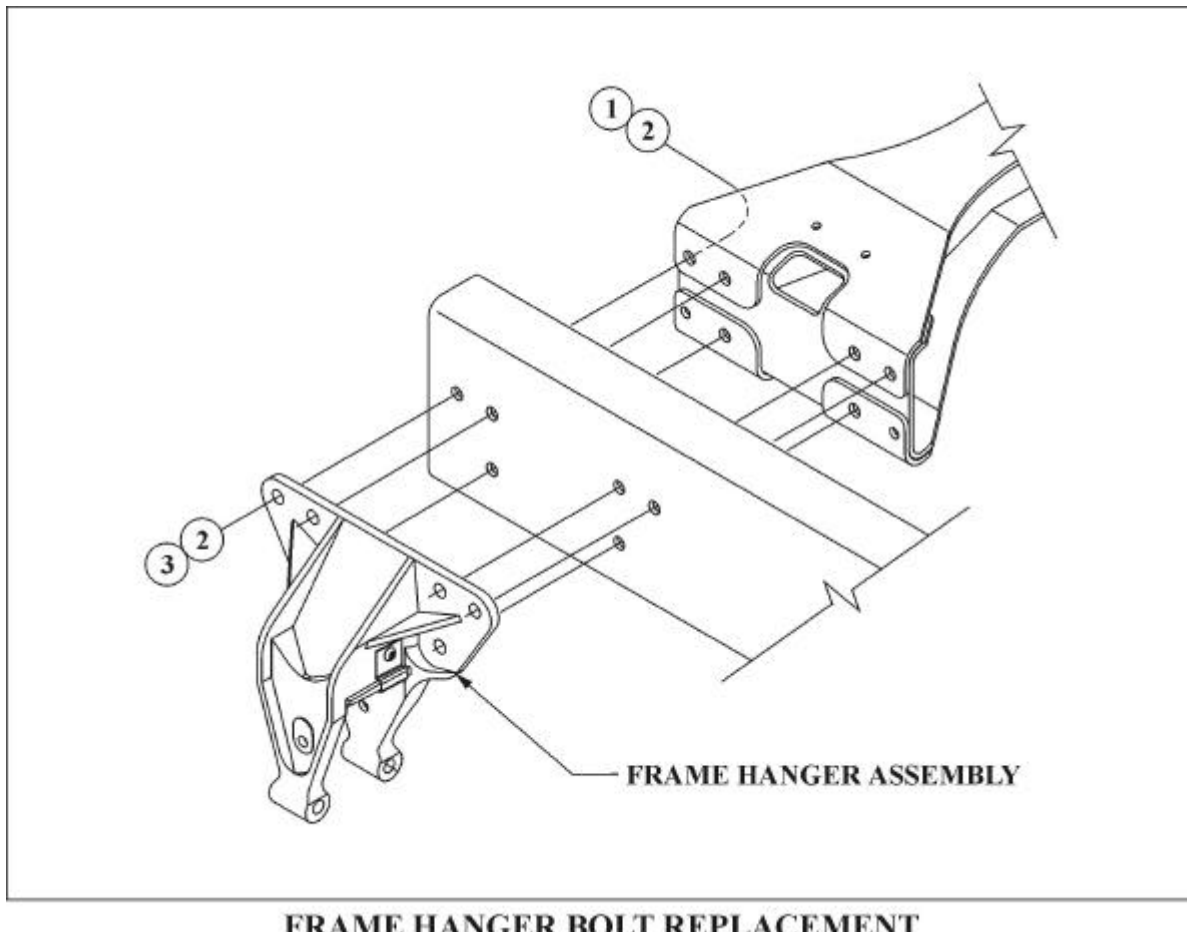

After all the procedures have been completed and checked, remove the jack stands and chocks.