

## R99CK

February 18, 1999

Dear Blue Bird Owner:

This notice is sent to you in accordance with the requirements of the National Traffic and Motor Vehicle Safety Act.

Blue Bird Body Company has determined that a defect which relates to motor vehicle safety exist in certain Blue Bird Micro Bird model buses. Subject buses are equipped with 30" or 34" seats and barriers or with 36", 39" or 45" seats and barriers with offset legs, installed in first body section behind driver. Blue Bird is conducting a recall to correct this defect.

The defect involves the fuel filler rubber hose on the subject buses. The fuel filler hose has a double wall with fill tube on inside and vent space on outside. When optional 30" or 34" barriers or optional 36", 39" or 45" seats with offset legs, are installed on the left side of the bus behind driver an additional floor reinforcement is installed. The fuel filler neck may chafe against the additional floor reinforcement.

Blue Bird Body Company's evaluation of the risk to motor vehicle safety reasonably related to this defect is the possibility that a fire hazard could result in the event a hole is chafed in the fuel filler hose and fuel vapors or liquid is released in the presence of an ignition source.

You should have this condition corrected immediately. Your Blue Bird bus(es) affected by recall R99CK are identified by body serial number(s) on the enclosed reply sheets. Follow the instructions on the enclosed **yellow** parts request sheet and return it to Blue Bird in the enclosed pink postage prepaid reply envelope.

Modification parts will be available beginning February 18, 1999. Modification parts will be shipped "No Charge" to you via UPS.

If you no longer own the subject bus(es), please complete the appropriate section of the yellow reply sheet and return to Blue Bird in the enclosed pink postage prepaid envelope.

**R99CK**

**Page 2**

You may perform this modification yourself or have the work done by a qualified repair facility convenient to you. You may contact your Blue Bird distributor for assistance. To obtain reimbursement for labor complete the enclosed **pink** reply sheet provided and return to Blue Bird in the enclosed pink postage prepaid envelope. Time required to perform recall R99CK is 18 minutes (0.3 hour) per bus

Important: Your prompt return of the pink reimbursement sheet, complete with the correct Body Serial Numbers, permits Blue Bird to update the record indicating recall has been completed and prevents the mailing of a second notice. This is much appreciated. We regret any inconvenience this may have caused.

If Blue Bird Body Company should fail to or is unable to remedy this condition without charge to you, you may contact:

**ADMINISTRATOR  
NATIONAL HIGHWAY TRAFFIC SAFETY ADMINISTRATION  
WASHINGTON, D.C. 20590**

or you may call The National Highway Traffic Safety Administration toll free at:

1-800-424-9393

Washington D.C. residents may call: 202-366-0123.

Questions regarding this recall campaign should be directed to me at (912) 822-2242.

Thank you,

Bill Coleman  
Recall Administrator

**BLUE BIRD BODY COMPANY**

**RECALL R99CK  
MICRO BIRD FUEL FILLER NECK SHIELD  
INSTALLATION INSTRUCTIONS**

1. Park bus on level surface.
2. Remove keys from ignition.
3. Locate longitudinal floor reinforcement channel that runs across fuel filler neck.
4. Inspect top side of rubber fuel filler neck for chafing. If chafing has rubbed a hole in the fuel filler neck contact your local distributor for the chassis for replacement fuel filler neck. Submit copy of parts invoice with pink reply sheet to Blue Bird to obtain reimbursement for parts.
5. Install shield (#0009114) over floor reinforcement channel. Be sure flange with four holes is on the outside of the channel.
6. Center shield (#0009114) over fuel filler neck. Push shield up onto floor reinforcement as far as possible.
7. Using holes in shield as a guide, drill four (4) 13/64" holes in outside flange of the floor reinforcement channel.

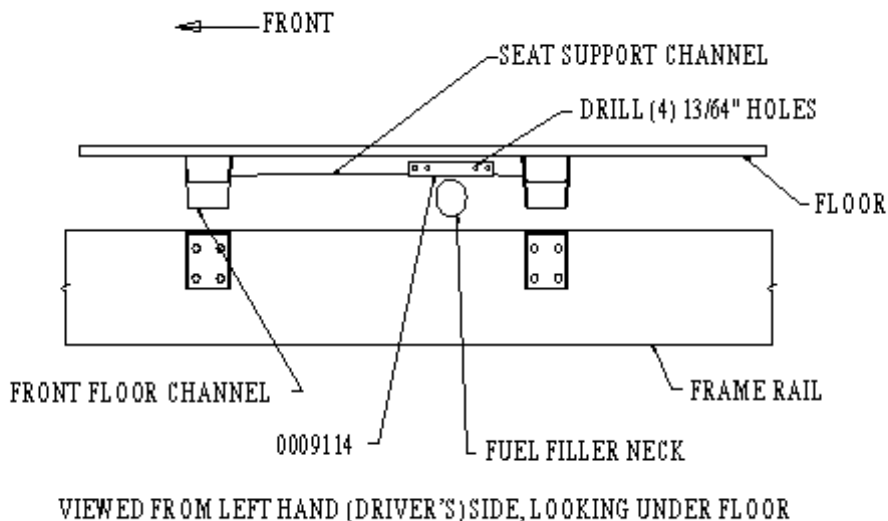

8. Using four #14, 1/4 x 3/4 screws (#1589530) fasten shield (#0009114) to floor reinforcement channel.

**February 16, 1999**

**MEMO TO: CANADIAN DISTRIBUTORS**

**SUBJECT: RECALL R99CK FUEL FILLER HOSE INTERFERENCE**

This notice is sent to you in accordance with the requirements of the Canadian Motor Vehicle Safety Act.

Blue Bird Body Company has determined that a defect which relates to motor vehicle safety exist in certain Blue Bird Micro Bird model buses. Subject buses are equipped with 30" or 34" seats and barriers or with 36", 39" or 45" seats and barriers with offset legs, installed in first body section behind driver. Blue Bird is conducting a recall to correct this defect. A copy of R99CK is attached.

The defect involves the fuel filler rubber hose on the subject buses. The fuel filler hose has a double wall with fill tube on inside and vent space on outside. When optional 30" or 34" barriers or optional 36", 39" or 45" seats with offset legs, are installed on the left side of the bus behind driver an additional floor reinforcement is installed. The fuel filler neck may chafe against the additional floor reinforcement.

A printout identifying affected units delivered in your service area is also enclosed.

Notification will be sent directly to owners. Modification kits for recall R99CK will be shipped "No Charge" via UPS. Time required to perform Recall R99CK is 18 minutes (0.3 hr.) per bus.

Owners are being advised they may perform this work themselves or have the work performed by a local repair facility. They may also contact their distributor for assistance. The owner notification for R99CK will include a labor reimbursement sheet, which will permit owners to file for reimbursement for labor directly to Blue Bird Body Company. For units modified by the distributor, warranty applications may be submitted to Blue Bird via BBOND (use CBCLAIM in warranty menu).

Should questions arise concerning this recall, please contact me at (912) 822-2242.

Sincerely,

Bill Coleman  
Recall Administrator

## **R99CK**

February 18, 1999

Dear Blue Bird Owner:

This notice is sent to you in accordance with the requirements of the Canadian Motor Vehicle Safety Act.

Blue Bird Body Company has determined that a defect which relates to motor vehicle safety exist in certain Blue Bird Micro Bird model buses. Subject buses are equipped with 30" or 34" seats and barriers or with 36", 39" or 45" seats and barriers with offset legs, installed in first body section behind driver. Blue Bird is conducting a recall to correct this defect.

The defect involves the fuel filler rubber hose on the subject buses. The fuel filler hose has a double wall with fill tube on inside and vent space on outside. When optional 30" or 34" barriers or optional 36", 39" or 45" seats with offset legs, are installed on the left side of the bus behind driver an additional floor reinforcement is installed. The fuel filler neck may chafe against the additional floor reinforcement.

Your Blue Bird bus(es) affected by recall R99CK are identified by body serial number(s) on the enclosed pink labor reimbursement sheet. If you no longer own the subject bus(es), please complete the appropriate section of the pink labor reimbursement sheet and return to Blue Bird at the address below.

Modification parts will be shipped to you "No Charge" via UPS. Time required to install the fuel filler hose shield is 18 minutes (0.3hr).

You may perform this modification yourself or have the work done by a qualified repair facility convenient to you. You may contact your Blue Bird distributor for assistance. Reimbursement for labor may be obtained by completing the pink request for reimbursement sheet provided and returning it to:

Attn: Recall Administrator  
Blue Bird Body Company  
P.O. Box 937  
Fort Valley, GA 31030

**R99CK**

Page 2

If Blue Bird Company should fail to or is unable to remedy this condition without charge to you, you may contact:

**RECALL OFFICER  
ROAD SAFETY TRANSPORT CANADA  
TOWER II CANADA BUILDING  
344 SLATER STREET  
OTTAWA, ONTARIO CANADA K1A 0H5**

or you may call The Road Safety Transport Canada toll free at:

1-800-333-0510

Questions regarding this recall campaign should be directed to me at (912) 822-2242.

Thank you,

Bill Coleman  
Recall Administrator

**BLUE BIRD BODY COMPANY**

## **FINAL NOTICE**

**DATE: JULY 13, 1999**

**TO: BLUE BIRD OWNERS**

**SUBJECT: RECALL R99CK FUEL FILLER HOSE AND FLOOR  
REINFORCEMENT INTERFERENCE**

According to our records, we have not receive a response to our recall notification R99CK dated March 18, 1999 pertaining to interference between the fuel filler hose and floor reinforcement.

If this is the first time you received notification of Recall R99CK, please read complete notification and follow the instructions provided. Return the yellow parts request sheet and we will ship parts as soon as possible via UPS.

If you have already received notification of Recall R99CK and have not received the appropriate modification parts, please complete the yellow parts request sheet and return to Blue Bird in the pink postage prepaid envelope as directed by the enclosed recall notification.

If you have already made the changes as outlined in the attached recall notification, please complete and mail the pink reply sheet to us in the postage paid pink reply envelope.

Thank you for your prompt attention to this matter.

Sincerely,

Bill Coleman  
Recall Administrator

**BLUE BIRD BODY COMPANY**