



BLUE BIRD

February 27, 2013

TO: NORTH AMERICAN DEALERS

SUBJECT: SERVICE BULLETIN S13WC REAR AIR SUSPENSION CROSSMEMBER INSPECTION

MODELS

AFFECTED: A3FE, A3RE, BBCV, D3FE, D3RE

On the subject buses, the rear air suspension crossmember may have developed cracks at mounting locations. The rear air suspension crossmember should be inspected for cracks in crossmember and replace with the new service crossmember as required.

A printout of your buses that are affected by Service Bulletin S13WC is also attached.

Time to inspect the rear air suspension crossmember for cracks per instructions for S13WC is 0.1 hours (6 minutes) per bus. If required, time to replace the rear air suspension for S13WC is 5.5 hours (5 hours, 30 minutes) which includes the inspection time.

Service Bulletin S13WC will be mailed directly to owners. Owners are being advised to contact their dealer for assistance, if needed.

Parts required to replace the rear air suspension crossmember must be ordered through Blue Bird Service Parts. Parts are available to be ordered.

Service Bulletin S13WC ends one (1) year from date of issue. Claims for repairs performed after the end date cannot be submitted to Blue Bird.

Questions regarding Service Bulletin S13WC should be directed to your Blue Bird Field Service Representative.

Sincerely,

Gerry Gibb
On behalf of Bill Coleman
Engineering Services
478-822-2060
gerry.gibb@blue-bird.com

BLUE BIRD BODY COMPANY

P.O. Box 937 – 402 Blue Bird Blvd – Fort Valley, Georgia – (478) 825-2021



BLUE BIRD

February 27, 2013

Dear Blue Bird Owner,

You will find enclosed a copy of Service Bulletin S13WC regarding the inspection of rear air suspension crossmembers on certain 2012 through 2014 model year All American transit and Blue Bird Vision model buses.

The rear air suspension crossmember may have developed cracks at mounting locations. The rear air suspension crossmember should be inspected for cracks in crossmember and replace with the new service crossmember as required.

Your buses affected by Service Bulletin S13WC are identified by Blue Bird body number under section 2 of the enclosed cover sheet.

You may contact your Blue Bird dealer to arrange to have Service Bulletin S13WC performed. Or, if you prefer, you may perform Service Bulletin S13WC yourself or have a qualified repair facility convenient to you perform this service bulletin. A qualified technician should perform Service Bulletin S13WC.

Time to inspect the rear air suspension crossmember for cracks per instructions for S13WC is 0.1 hours (6 minutes) per bus. If required, time to replace the rear air suspension for S13WC is 5.5 hours (5 hours, 30 minutes) which includes the inspection time.

Parts required to perform Service Bulletin S13WC must be ordered through your Blue Bird dealer. Parts are available to be ordered.

Service Bulletin S13WC ends one (1) year from date of issue. Claims for repairs performed after the end date cannot be submitted to Blue Bird.

Should you have any questions concerning this bulletin, please contact your Blue Bird dealer.

Sincerely,

Gerry Gibb
On behalf of Bill Coleman
Engineering Services
478-822-2060
gerry.gibb@blue-bird.com

BLUE BIRD BODY COMPANY
P.O. Box 937 – 402 Blue Bird Blvd – Fort Valley, Georgia – (478) 825-2021



Rear Air Suspension Crossmember Inspection

BULLETIN

**Models Affected: Certain 2012-2014 Model Year All Americans & Visions
with Optional Rear Air Suspension**

ISSUE

Rear air suspension crossmember may have developed fatigue cracks at mounting locations.

CORRECTIVE ACTION

Inspect for cracks in crossmember and replace with new service crossmember as required.

PROCEDURE

WARNING: Always follow all Federal, State, Local and Shop safety standards and use proper safety equipment, and thoroughly read and understand all instructions before performing these procedures.

WARNING: Be sure to keep head, hands and arms clear of the moving portion of the suspension. Prior to and during the draining of air system ensure that all personnel and equipment are clear from under the frame rails, luggage boxes or any other components that can crush or otherwise cause serious personal injury, death or property damage.

All Products

Inspection

1. Park the bus on a level surface, apply parking brake, turn off ignition, remove ignition key, and chock wheels.
2. Drain all air tanks and disconnect leveling valve rod and lower arm to deflate air suspension to its lowest position.
3. From underneath the bus, in front of the rear axle, inspect each end of crossmember at all 8 frame rail mounting hole locations for possible cracks. (See figures 1 & 2)

Note: Clean surface of crossmember to inspect for possible cracks.

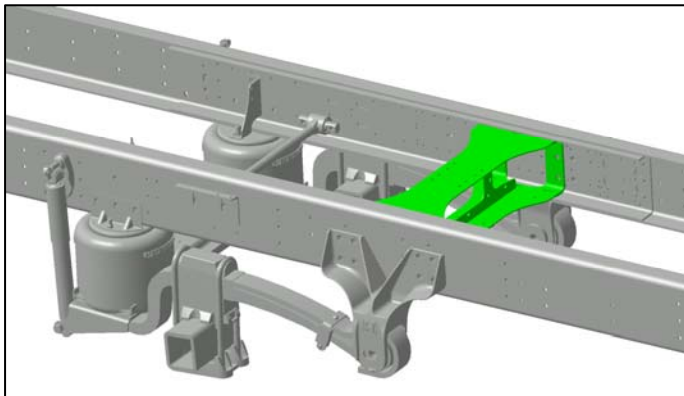

Fig. 1

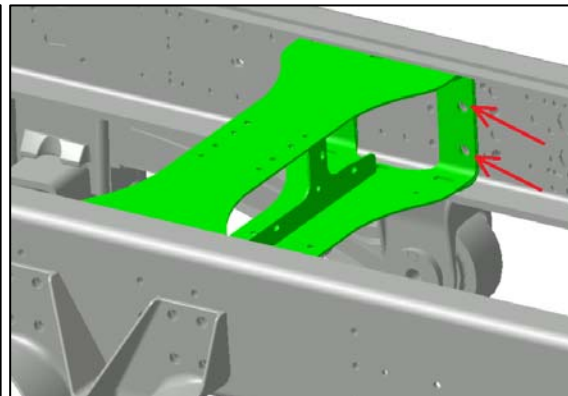

Fig. 2



4. If no cracks are found then restore bus back to operating condition and place back in normal service.
5. If cracks are present, then replace crossmember with new service crossmember kit BB# 10033035.

Parts List		
BB Part #	Description	Quantity
10033035	KIT,CROSSMEMBER,SERVICE,AIR SUSP,RR	1

D3RE Only

On D3RE's, the rearward DEF tank mounting bracket will have to be replaced with bracket 10018315. (Fig. 3) Use existing tank bracket fasteners and isolators to reinstall tank. (Fig. 4)

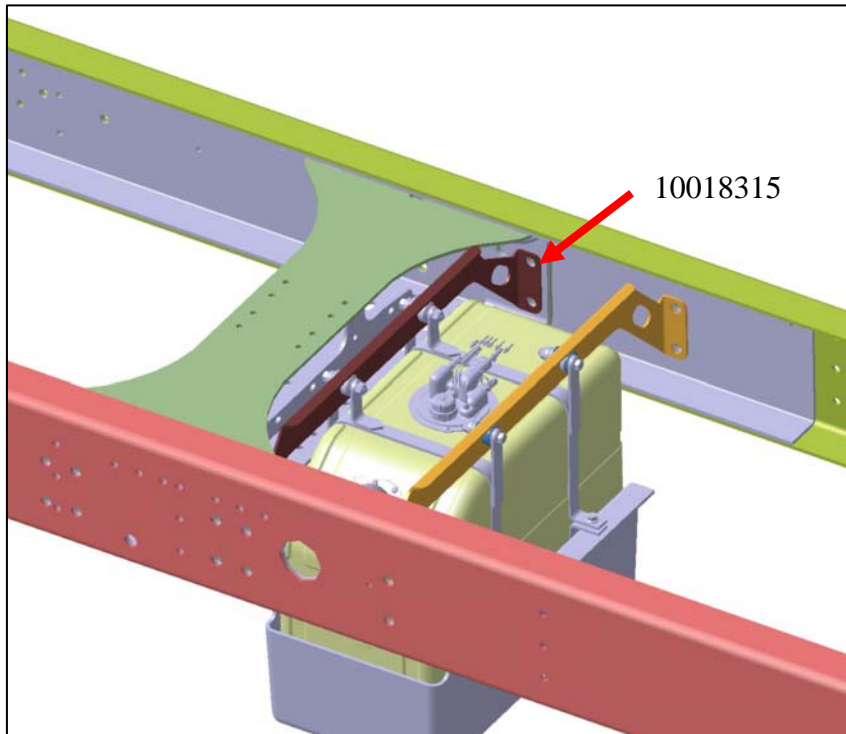

Fig. 3

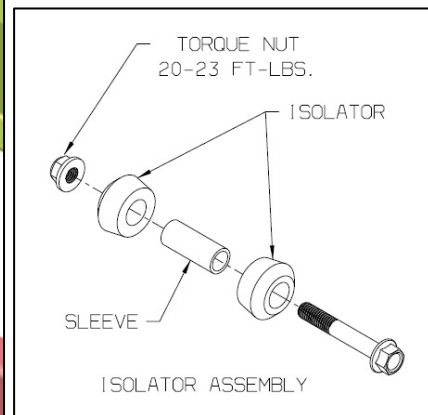

Fig. 4

Parts List		
BB Part #	Description	Quantity
10018315	BRACKET ASSY,MTG,DEF TANK,31.88 D3RE	1