



Service Data

SD-03-3619

Bendix® PP-DC™ Park Control Valve

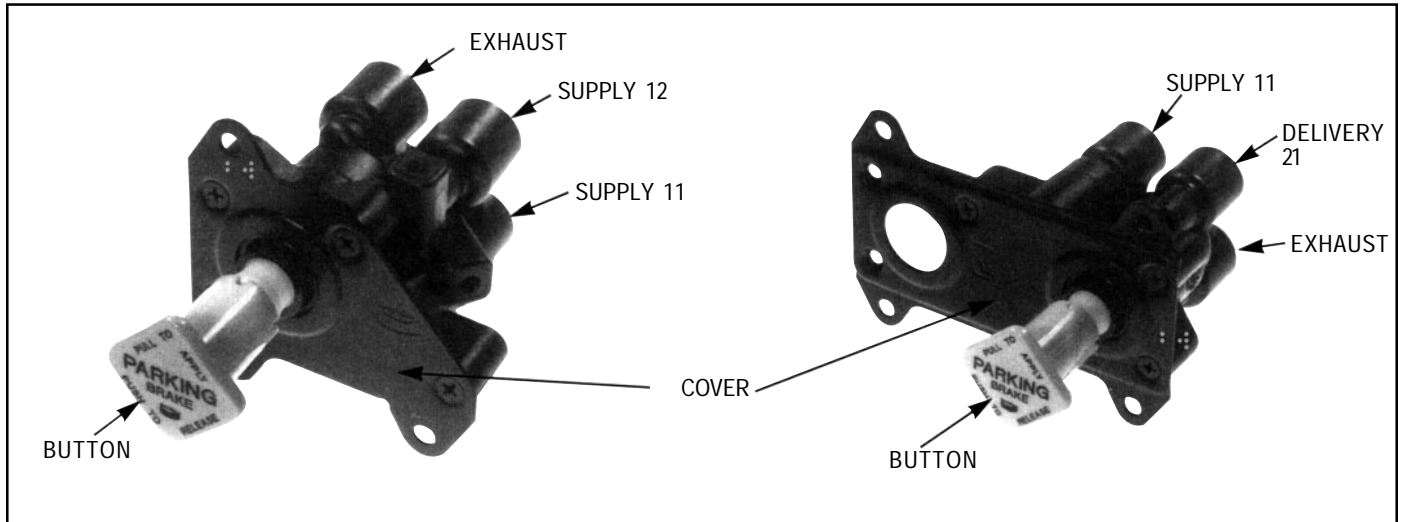

FIGURE 1 - PP-DC™ PARK CONTROL VALVE

DESCRIPTION

The Bendix® PP-DC™ park control valve is a push-pull, manually operable on/off valve. It is dash board-mounted and provides in-cab control of truck or bus parking brakes.

The valve is pressure sensitive – it automatically moves from the applied to the exhaust position if total system pressure drops below 20 to 30 psi. Also, manually pulling the button will apply the parking brakes.

The PP-DC™ valve body is made of non-metallic, non-corrosive material, and the cover is available in two mounting variations (see Figure 1). The valve is designed to accept 1/4" P.T. fittings or push-to-connect fittings that use SAE J844D non-metallic air brake tubing.

Ports:

Port	Embossed I.D.
Primary Reservoir Supply	Supply 11
Secondary Reservoir Supply	Supply 12
Delivery	Delivery 21
Exhaust	Exhaust 3

Operating pressure: 150 psi max.

Operating temperature: -40° to 200°F

Basic valve weight: Approximately .8 lbs.

OPERATION

GENERAL

The PP-DC™ valve receives its supply of air from the primary service reservoir or the secondary service reservoir, whichever is at the higher pressure. When the button is pushed in, the valve delivers air to the spring brake chambers (usually through a spring brake valve such as the Bendix® SR-1™ valve and a relay or quick release valve). The air releases the spring brakes for normal vehicle operation.

To apply the parking brakes, the button is pulled out, which exhausts the PP-DC™ valve delivery and releases air from the spring brake chambers.

If total system pressure drops below 20 to 30 psi, the valve will automatically “pop out,” which removes the hold-off air in the chambers and applies the spring brakes.

PARKING BRAKES RELEASED

To release the parking brakes, the push-pull button is pushed in. The PP-DC™ valve plunger moves, closing the exhaust port with the exhaust seal and allowing the plunger o-ring to move past the guide spool. Supply air then travels out the delivery port to release the brakes.

Note that Figure 3 shows the primary service reservoir supplying the PP-DC™ valve. The double check valve diaphragm has sealed the secondary reservoir supply port and allows air to pass from the primary reservoir into the PP-DC™ valve.

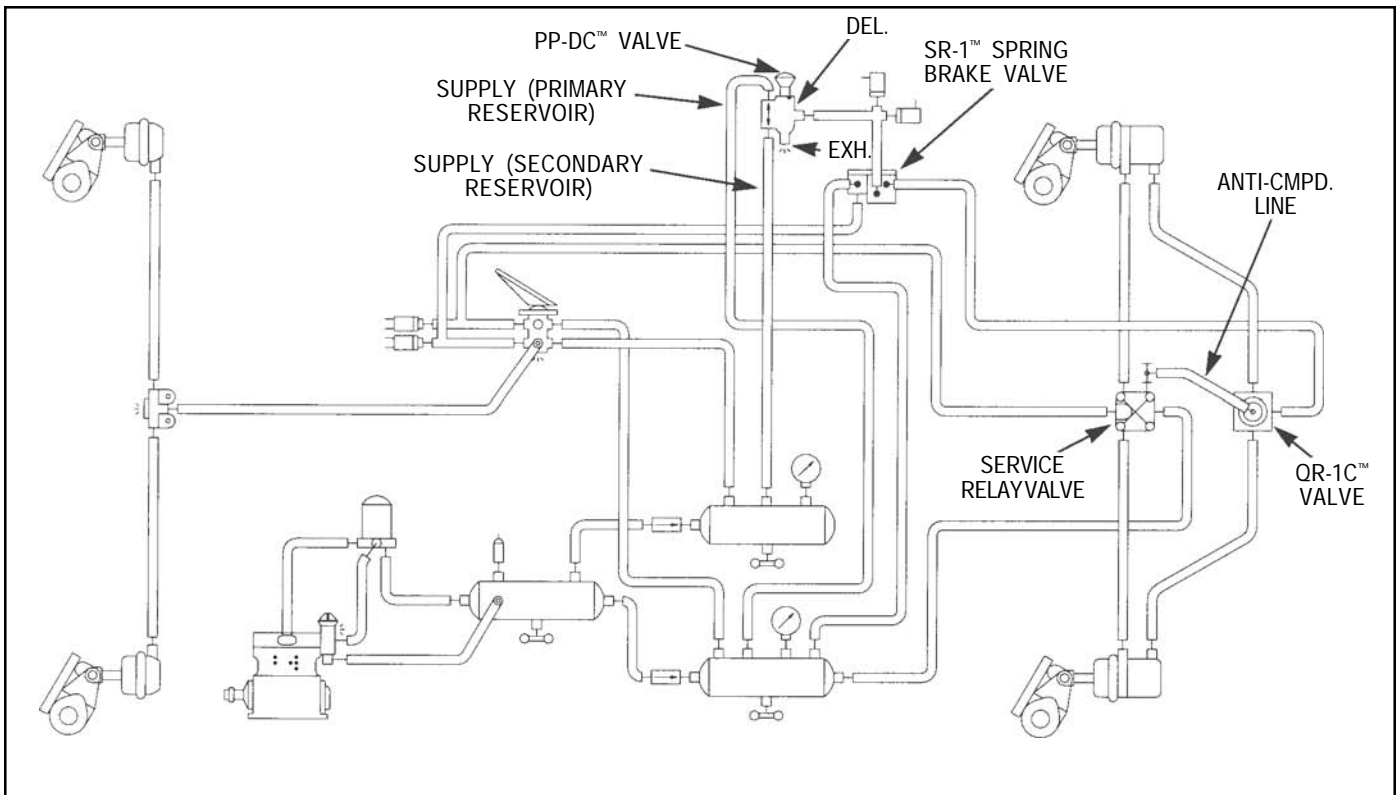

FIGURE 2 - TYPICAL 4 X 2 TRUCK SCHEMATIC WITH PP-DC™ PARK CONTROL VALVE

If primary service reservoir pressure drops below secondary service reservoir pressure, the double check valve reacts as shown in Figure 4. It seals the primary service reservoir supply port and supplies the PP-DC™ valve with air from the secondary service reservoir. As is shown, the push-pull button remains in and the spring brakes remain released.

PARKING BRAKES APPLIED

Figure 5 shows the PP-DC™ valve in the parking-brakes-applied position. This will occur if the driver manually pulls out the push-pull button or if total system pressure drops to below 20 to 30 psi.

When the button “pops out,” the exhaust seal moves to open the exhaust port to atmosphere, allowing delivery line pressure to exhaust. The plunger o-ring moves to seal off supply pressure. Spring brake hold-off air is exhausted through the spring brake relay valve.

WARNING! PLEASE READ AND FOLLOW THESE INSTRUCTIONS TO AVOID PERSONAL INJURY OR DEATH:

When working on or around a vehicle, the following general precautions should be observed at all times.

1. Park the vehicle on a level surface, apply the parking brakes, and always block the wheels. Always wear safety glasses.
2. Stop the engine and remove ignition key when working under or around the vehicle. When working in the engine compartment, the engine should be shut off and the ignition key should be

removed. Where circumstances require that the engine be in operation, **EXTREME CAUTION** should be used to prevent personal injury resulting from contact with moving, rotating, leaking, heated or electrically charged components.

3. Do not attempt to install, remove, disassemble or assemble a component until you have read and thoroughly understand the recommended procedures. Use only the proper tools and observe all precautions pertaining to use of those tools.
4. If the work is being performed on the vehicle's air brake system, or any auxiliary pressurized air systems, make certain to drain the air pressure from all reservoirs before beginning **ANY** work on the vehicle. If the vehicle is equipped with an AD-IS® air dryer system or a dryer reservoir module, be sure to drain the purge reservoir.
5. Following the vehicle manufacturer's recommended procedures, deactivate the electrical system in a manner that safely removes all electrical power from the vehicle.
6. Never exceed manufacturer's recommended pressures.
7. Never connect or disconnect a hose or line containing pressure; it may whip. Never remove a component or plug unless you are certain all system pressure has been depleted.
8. Use only genuine Bendix® replacement parts, components and kits. Replacement hardware, tubing, hose, fittings, etc. must be of equivalent size, type and strength as original equipment and be designed specifically for such applications and systems.

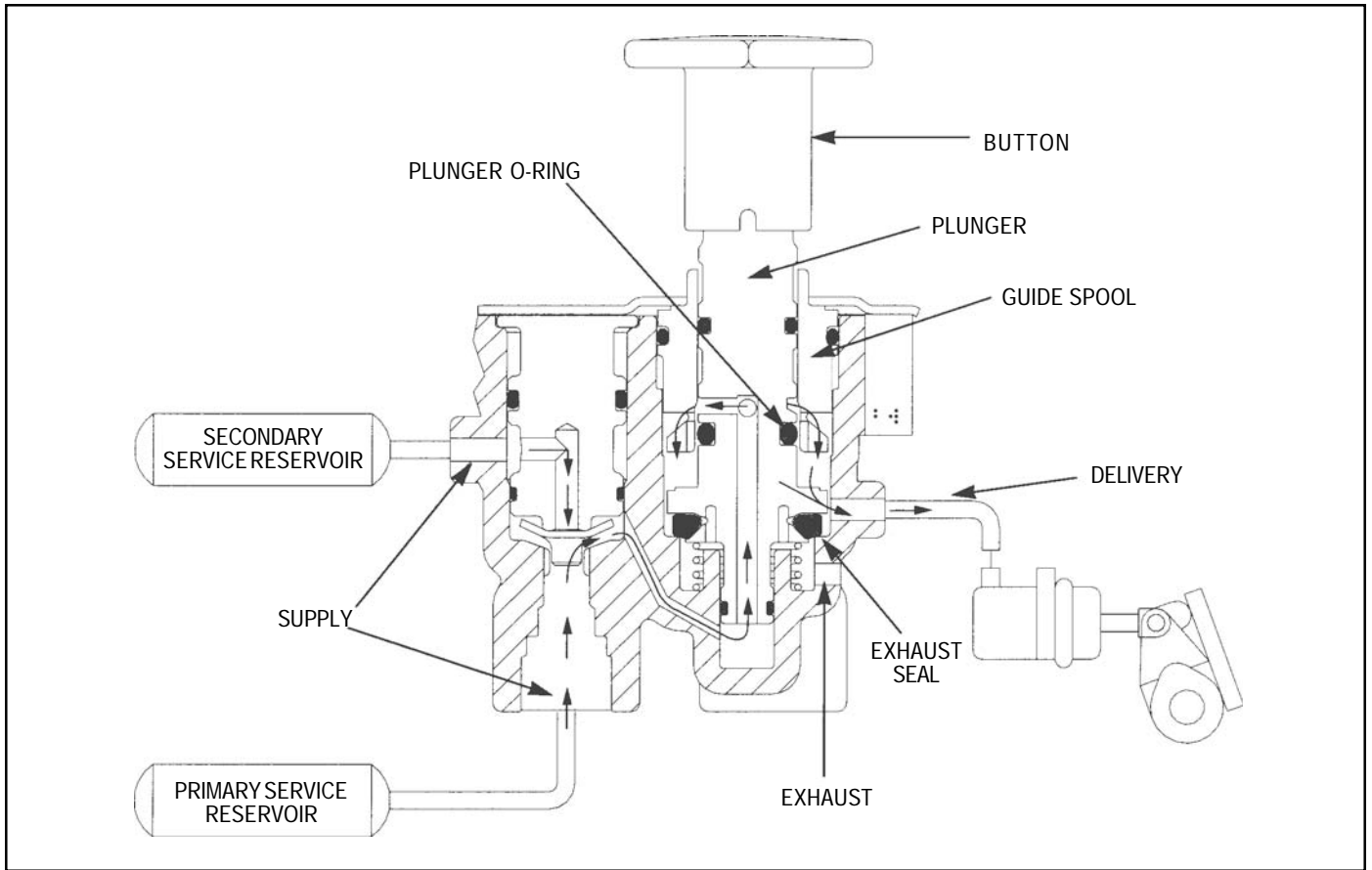

FIGURE 3 - SPRING BRAKES RELEASED (PRIMARY RESERVOIR SUPPLY)

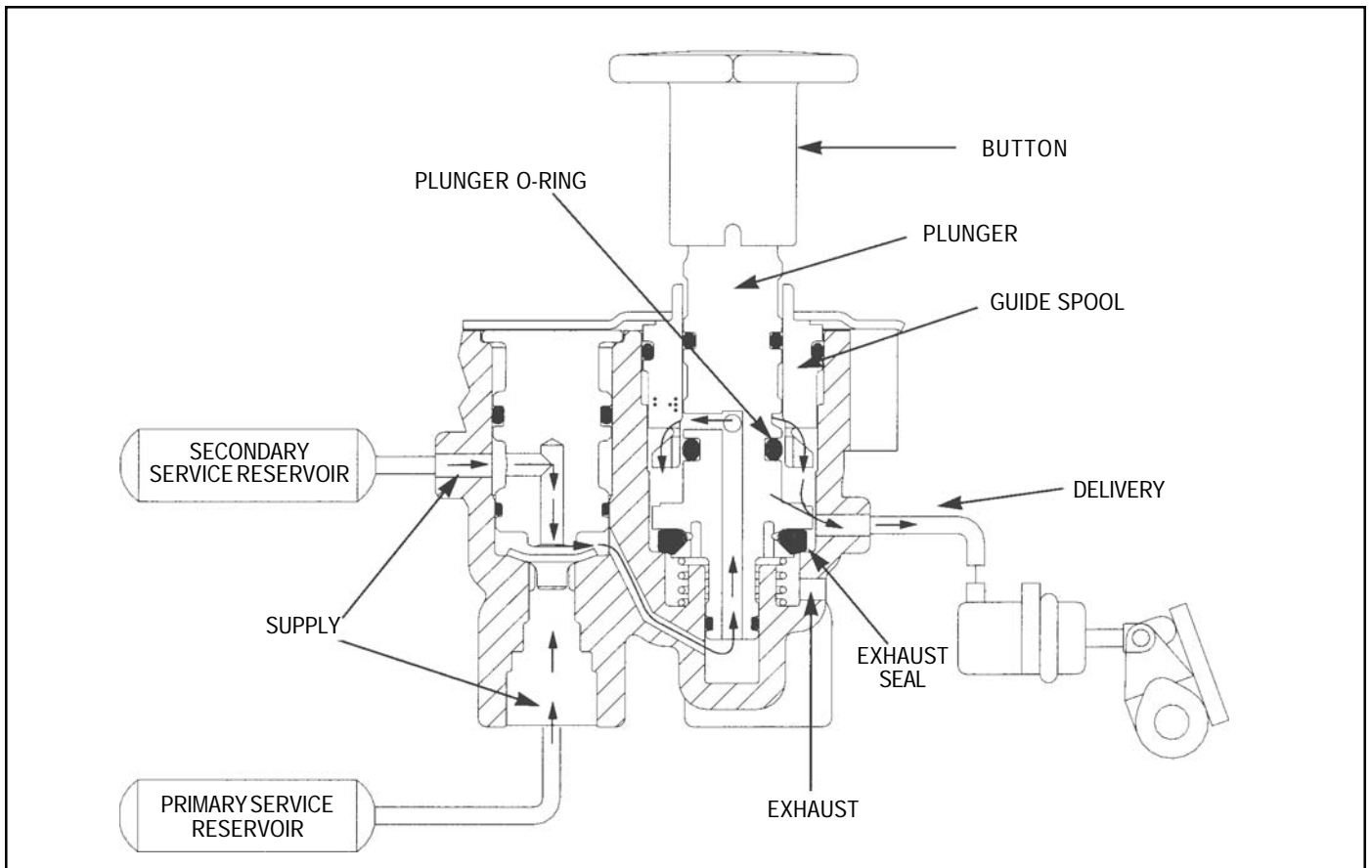

FIGURE 4 - SPRING BRAKES RELEASED (SECONDARY RESERVOIR SUPPLY)

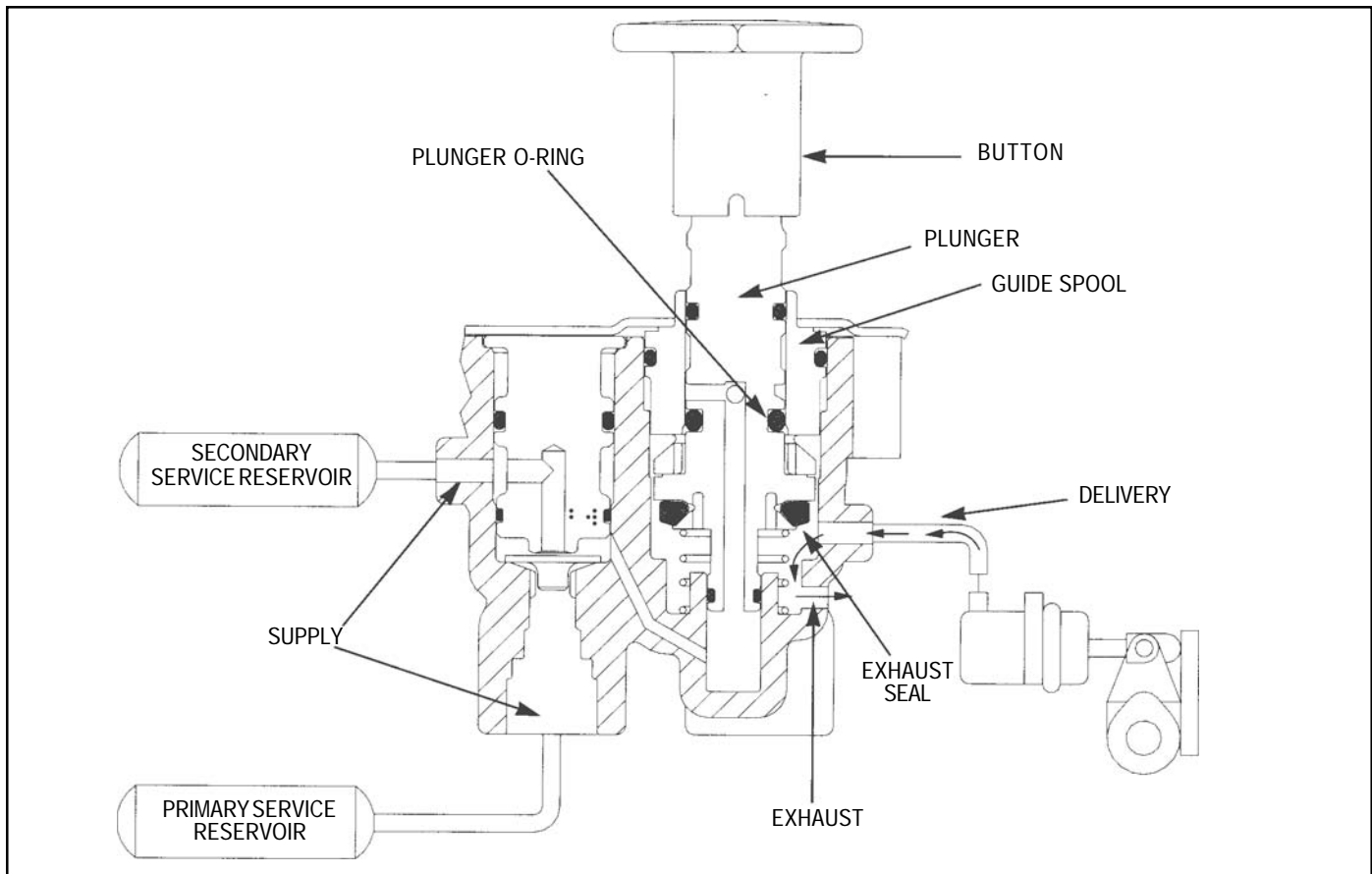

FIGURE 5 - PARKING BRAKES APPLIED

9. **Components with stripped threads or damaged parts should be replaced rather than repaired. Do not attempt repairs requiring machining or welding unless specifically stated and approved by the vehicle and component manufacturer.**
10. **Prior to returning the vehicle to service, make certain all components and systems are restored to their proper operating condition.**
11. **For vehicles with Antilock Traction Control (ATC), the ATC function must be disabled (ATC indicator lamp should be ON) prior to performing any vehicle maintenance where one or more wheels on a drive axle are lifted off the ground and moving.**

PREVENTIVE MAINTENANCE

Important: Review the Bendix Warranty Policy before performing any intrusive maintenance procedures. A warranty may be voided if intrusive maintenance is performed during the warranty period.

No two vehicles operate under identical conditions, as a result, maintenance intervals may vary. Experience is a valuable guide in determining the best maintenance interval for air brake system components. At a minimum, the PP-DC™ valve should be inspected every 6 months or 1500 operating hours, whichever comes first, for proper operation. Should the PP-DC™ valve not meet the elements of the operational tests noted in this document, further investigation and service of the valve may be required.

SERVICE CHECKS

1. Remove any accumulated contaminants. Visually inspect the valve's exterior for excessive wear or physical damage. Repair/replace as necessary.
2. Inspect all air lines connected to the valve for signs of wear or physical damage. Repair/replace as necessary.
3. Test air line fittings for excessive leakage. Repair/replace as necessary.

LEAKAGE AND OPERATIONAL TESTS

To perform the following tests, connect two separate 120 psi air sources to the PP-DC™ valve supply ports. Tee an accurate test gauge into the supply lines, and provide for a means to control supply line pressure. Connect a small volume with a gauge to the delivery port.

LEAKAGE TEST

1. Supply the valve with 120 psi from the primary reservoir supply port. With the button out, coat the exhaust port and the plunger stem with a soap solution. Leakage should not exceed a 1" bubble in 5 seconds. There should be no leakage from the secondary reservoir supply port.
2. With the button out, supply the valve with 120 psi from the secondary reservoir supply port. There should be no leakage from the primary reservoir supply port.

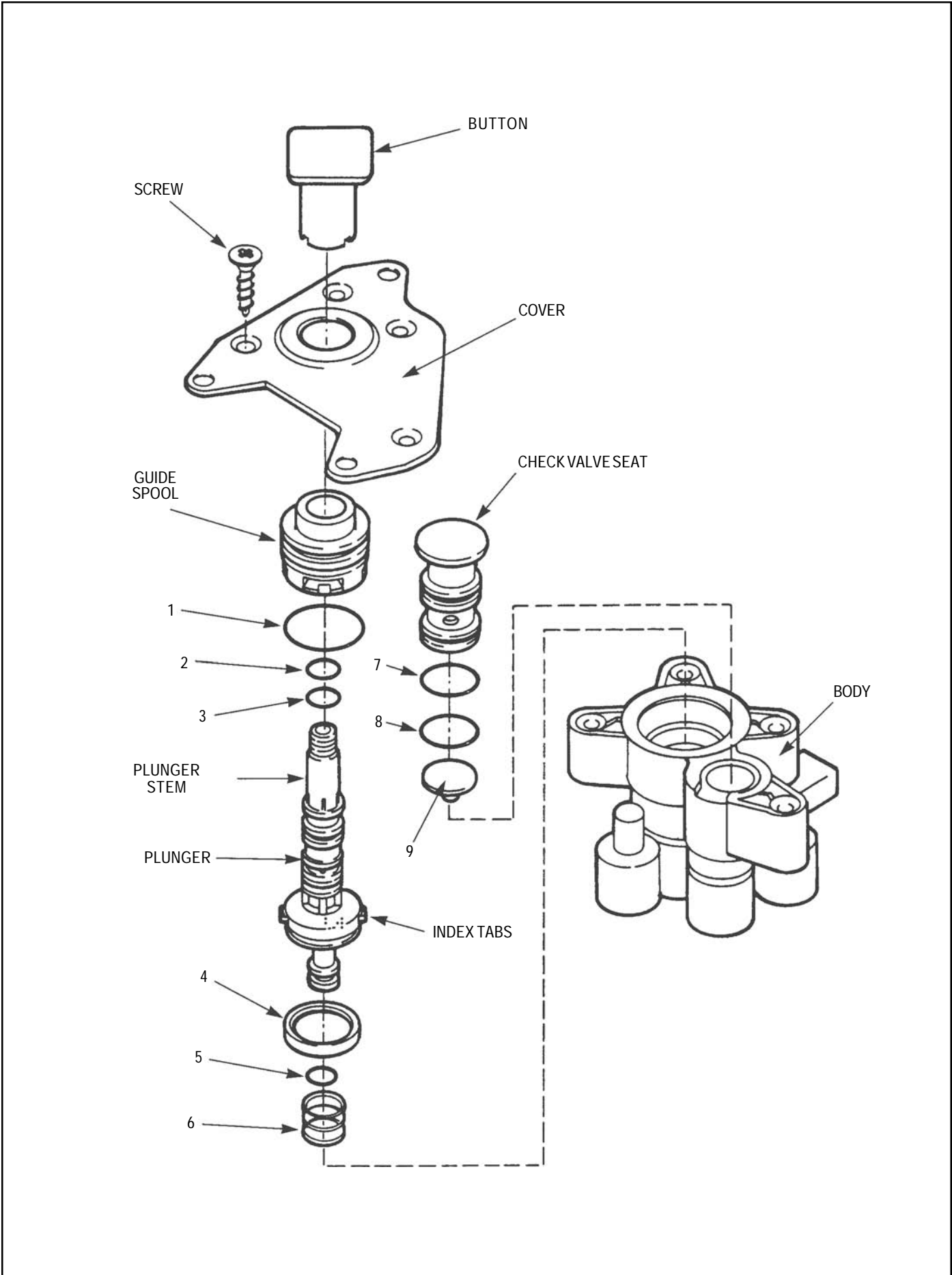

FIGURE 6 - EXPLODED VIEW

3. With the button in, coat the exhaust port and the plunger stem with a soap solution. Leakage at both areas should not exceed a 1" bubble in 3 seconds.

OPERATIONAL TEST

1. With the button out, supply either supply port with 120 psi of air. Then push the button in. Air pressure should rise in the delivery volume equivalent to supply pressure.
2. Pull the button out. Delivery pressure should exhaust to 0 psi.
3. Build each supply source to 120 psi. Decrease supply pressure at the secondary service reservoir supply port at a rate of 10 psi per second. Primary supply pressure and delivery pressure should not drop below 100 psi. Repeat the test for decreasing primary service reservoir pressure.
4. Build each supply source to 120 psi. Then decrease both supply pressures to below 20 to 30 psi. The button should automatically "pop" out when pressure drops within that range.

If the PP-DC™ valve fails to function as described, or if leakage is excessive, repair the valve or replace it at the nearest authorized Bendix Commercial Vehicle Systems parts outlet.

REMOVAL

1. Identify and mark or label all air lines and their connections on the valve.
2. Remove the PP-DC™ valve from the vehicle and save the mounting hardware.

INSTALLATION

1. Install the PP-DC™ valve in its location on the dashboard. Using the mounting hardware saved in "REMOVAL," secure the valve to the vehicle.
2. Reconnect all air lines to the valve using the identification made in "REMOVAL."
3. Perform "OPERATIONAL AND LEAKAGE TESTS" before placing the vehicle back in service.

DISASSEMBLY

The following disassembly and assembly procedures are for reference only. Always have the appropriate maintenance kit on hand and use its instructions in lieu of those presented here. Refer to Figure 6 throughout the procedure.

1. Turn the button counterclockwise to remove it from the plunger stem.
2. Remove the four screws that secure the cover to the body, and remove the cover.
3. Pull the plunger stem to remove the plunger and the guide spool from the body.
4. Remove plunger spring(6) and discard.

5. If necessary, use a screwdriver to carefully remove the check valve seat from the body. Be sure not to damage the check valve seat or the body.
6. Remove and discard check valve seat o-rings(7) and (8).
7. Turn the body upside down and gently tap it on a flat surface to remove check valve(9). Discard the check valve.
8. Remove the guide spool from the plunger. Remove and discard o-ring(1) from the guide spool.
9. Remove and discard o-rings(2), (3) and (5) from the plunger. Also remove and discard exhaust seal(4).

CLEANING & INSPECTION

1. Wash all metal parts in mineral spirits and thoroughly dry.
2. Inspect all re-usable parts for excessive wear or damage. Inspect the body for gouges or deep scuffing. Replace key numbers 1-9 (and any parts not determined usable) with genuine Bendix replacements.

ASSEMBLY

Before assembly, lubricate all o-rings, o-ring grooves, rubbing surfaces and bores with Bendix silicone lubricant (Pc. No. 291126) or equivalent.

1. Place check valve(9) into its seat in the body with its flat surface facing upward. If necessary, reach into the body to make sure the valve is seated evenly in the bore.
2. Install o-rings(7) and (8) on the check valve seat and install the check valve seat into the body. Make sure the seat is fully seated-its surface should be even with the body's surface.
3. Install plunger spring(6) into the body. Make sure it stands upright and is seated properly in the body bore. (It should surround the protrusion or "lip" at the bottom of the body bore.)
4. Install o-rings(2), (3), (5) and exhaust seal(4) onto the plunger. Then install the plunger into the body. Line up the plunger's index tabs with the spaces in the body bore for ease of installation.
5. Install o-ring(1) onto the guide spool. Then install the guide spool over the plunger and into the body. Press the guide spool into place firmly.
6. Place the cover onto the body and secure with its four screws. Torque to 35 in. lbs.
7. Thread the button clockwise onto the plunger stem. It should take approximately 3 full button revolutions to install it on the plunger. The protrusions on the side of the plunger should line up with the button grooves. Push on the button a number of times to make sure the plunger moves freely throughout its range of motion.

NOTE: BEFORE PLACING THE VEHICLE BACK INTO SERVICE, PERFORM THE "LEAKAGE AND OPERATIONAL TESTS" IN THIS MANUAL.