



Service Data

SD-13-4870

Bendix® M-32™ and M-32QR™ AntiLock Modulators

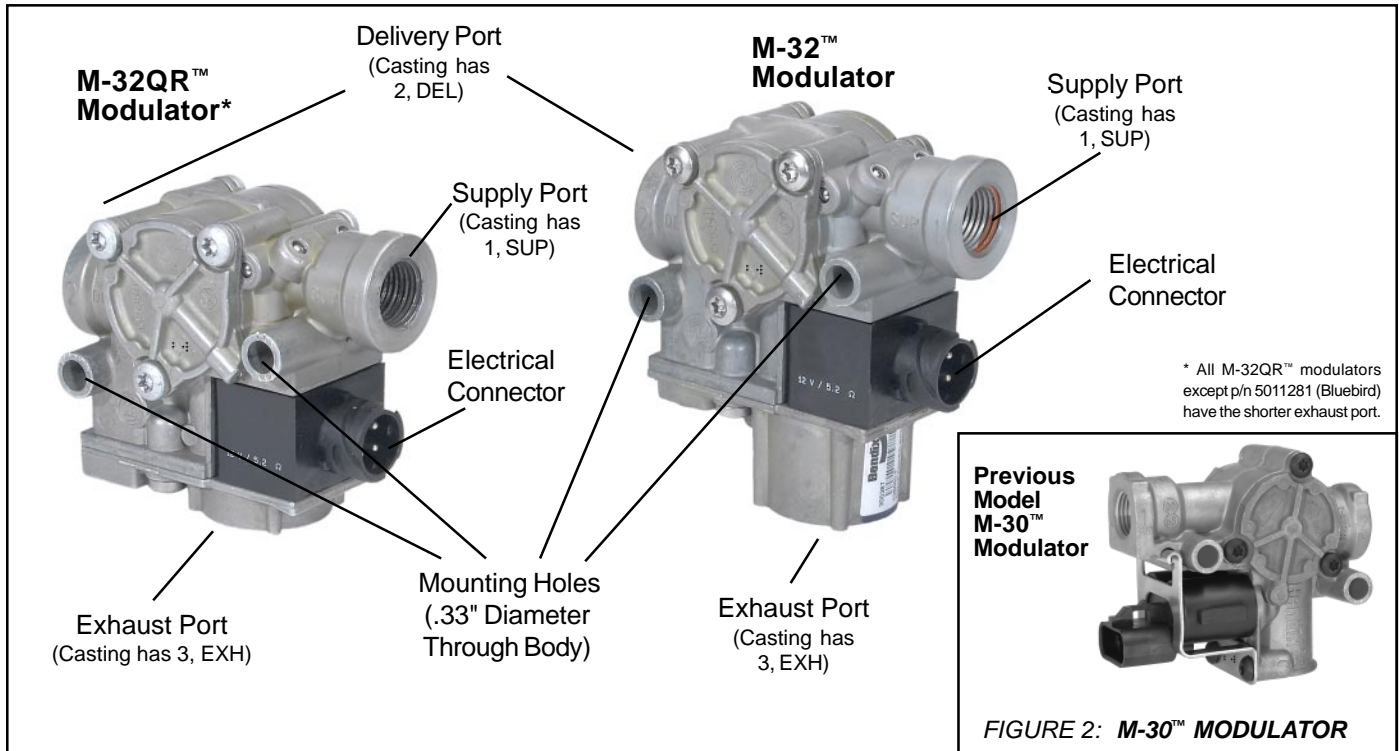

FIGURE 1: M-32™ AND M-32QR™ MODULATORS

DESCRIPTION

The M-32™ and M-32QR™ (quick release) antilock system modulators (Figure 1) are high capacity, on/off air valves that incorporate a pair of electrical solenoids for control. The solenoids provide the electro-pneumatic interface between the antilock controller electronics and the air brake system. The modulator is used to control the braking function on individual or dual service actuators during antilock activity.

The M-32QR™ modulator is the direct replacement for the M-30™ (Figure 2) modulator in all applications. The M-32QR™ modulator includes a bias valve to provide an internal quick release function. In applications using an M-32™ modulator, an external quick release valve may be required, depending on the system design (see Figure 3 for typical system schematics). When used to control both service chambers on an axle or two chambers on the same side of a tandem axle, the modulator is sometimes mounted ahead of a quick release valve, which provides quick exhaust of service applications during normal braking. In the case of individual wheel control applications, the modulator is always the last control valve through which air passes on its way to the service brake actuator.

The modulator consists of a die cast aluminum body and a solenoid assembly which contains one normally open solenoid, one normally closed solenoid, and an inlet and exhaust diaphragm valve. A three pin, weather resistant electrical connector is an integral part of the modulator solenoid assembly and serves to carry control commands from the antilock controller to the modulator. Two mounting holes are provided for frame or cross member mounting of the valve.

The supply, delivery and exhaust ports on the M-32™ modulator are identified with a cast, embossed numeral for positive identification.

Identification

1, SUP	Supply
(incoming air from foot, relay or quick release valve)	
2, DEL	Delivery
(air delivery to service actuators)	
3, EXH	Exhaust

Air Line Connection

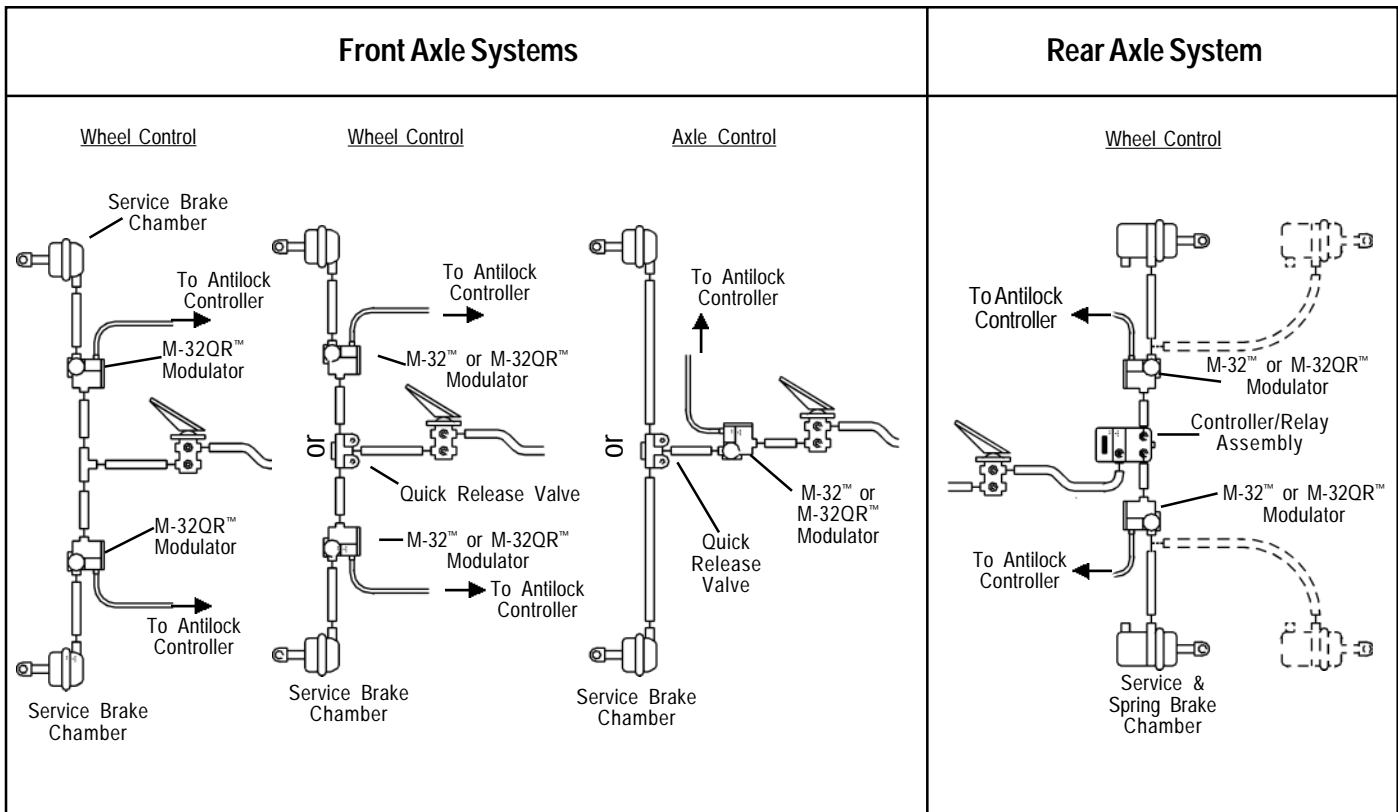

FIGURE 3: TYPICAL WHEEL AND AXLE CONTROL SYSTEMS

NOTE: use of a quick release valve is not typically required with the M-32QR™ modulator. Refer to vehicle specifications for recommended configuration.

FUNCTIONAL CHECK

A wiring harness connects the vehicle modulators to the controller. The ABS controller is able to simultaneously and independently control the individual modulators. When vehicle power is supplied to the ABS ECU, a modulator "chuff" test is performed. When the brake pedal is depressed and the ignition turned on, the modulator "chuff" test can be heard. This test will verify if the modulator is functioning pneumatically correct. The modulators will exhaust air in the sequence of right front, left front, right rear, left rear. If they do not follow this sequence, proceed with modulator troubleshooting.

OPERATION

NON-ANTILOCK BRAKE APPLICATION (Figure 4)

During normal, non antilock braking, both solenoids are de-energized (no electrical power). Brake application air enters the Supply port of the modulator and flows to the exhaust diaphragm. Air pressure, along with spring force, seats the exhaust diaphragm on the exhaust passage, thus preventing the escape of service air. Simultaneously, application air flows to the supply diaphragm and forces it away from its seat. Air flows past the open supply port and out the modulator delivery port to the service brake chambers.

NON-ANTILOCK HOLD (Figure 5)

When the desired air pressure is attained in the service brake chambers, the brake system is in the Holding position. In the Holding position, both solenoids in the modulator remain de-energized and the balance of the internal components remain in the same position as they assumed during application.

NON-ANTILOCK EXHAUST

The manner in which air exhausts through the modulator differs depends upon how rapidly the brake application is released by the driver.

Normal Exhaust (Figure 6) - During a normal, relatively "slow" brake release, air moves back through the modulator in the reverse direction as it flowed during application. The internal components of the modulator will remain in the same position as they assumed during application until air pressure decreases to approximately one half psi, at which time the supply diaphragm will seat on the supply passage. A relatively small amount of air will generally be expelled from the modulator exhaust port during "slow" brake release.

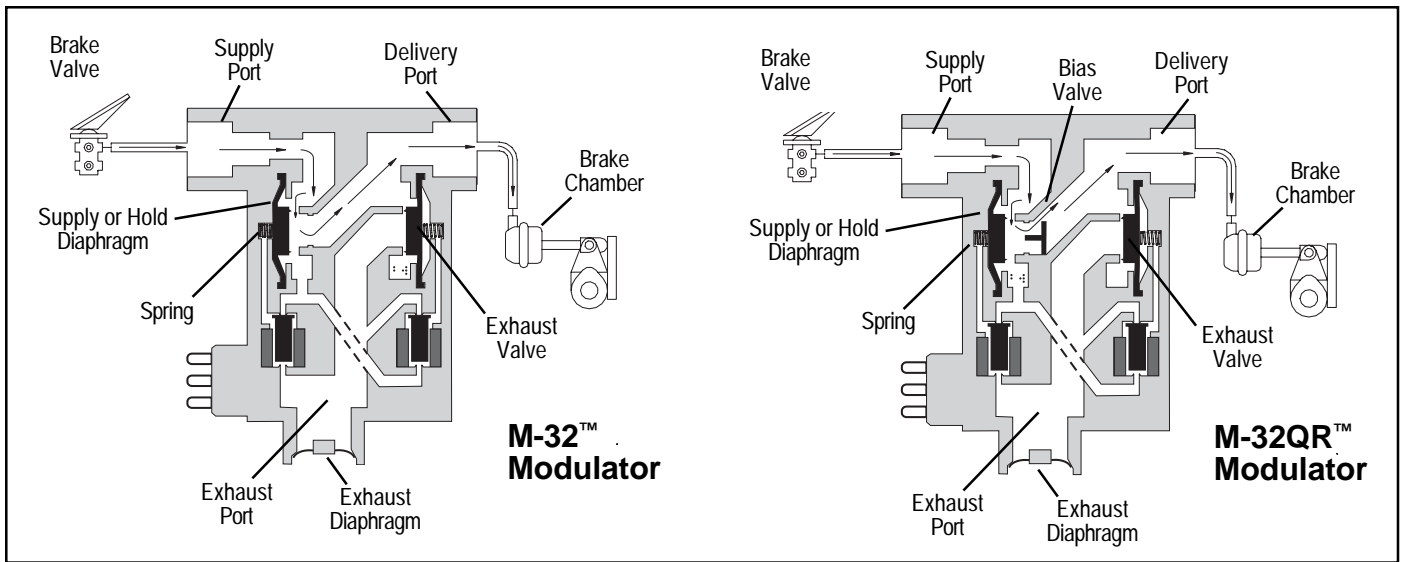

FIGURE 4: M-32™ AND M-32QR™ MODULATORS NON-ANTILOCK APPLICATION OF SERVICE BRAKES

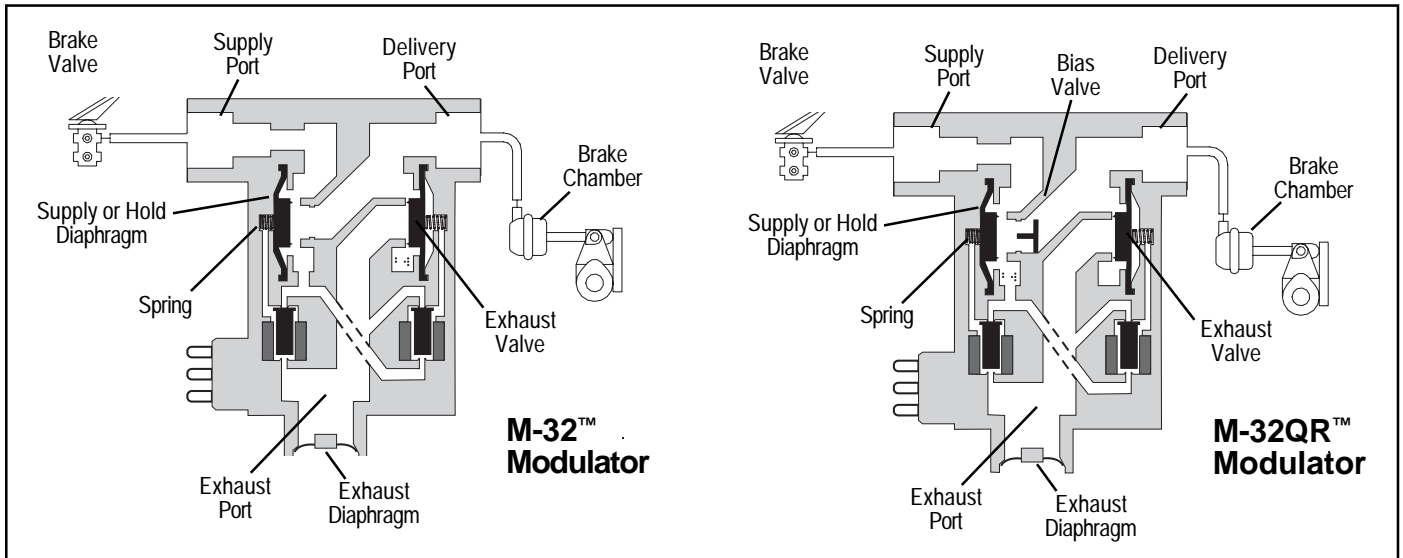

FIGURE 5: M-32™ AND M-32QR™ MODULATORS NON-ANTILOCK BRAKE APPLICATION HELD POSITION

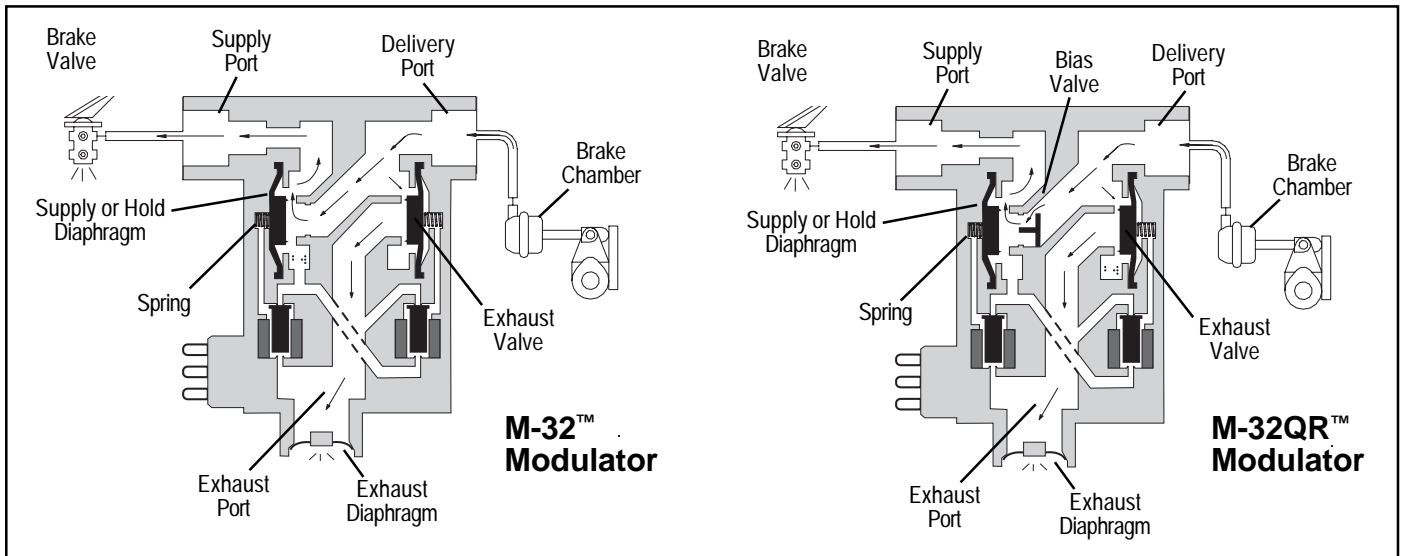

FIGURE 6: M-32™ and M-32QR™ MODULATORS "SLOW" NON-ANTILOCK EXHAUST OF SERVICE BRAKES

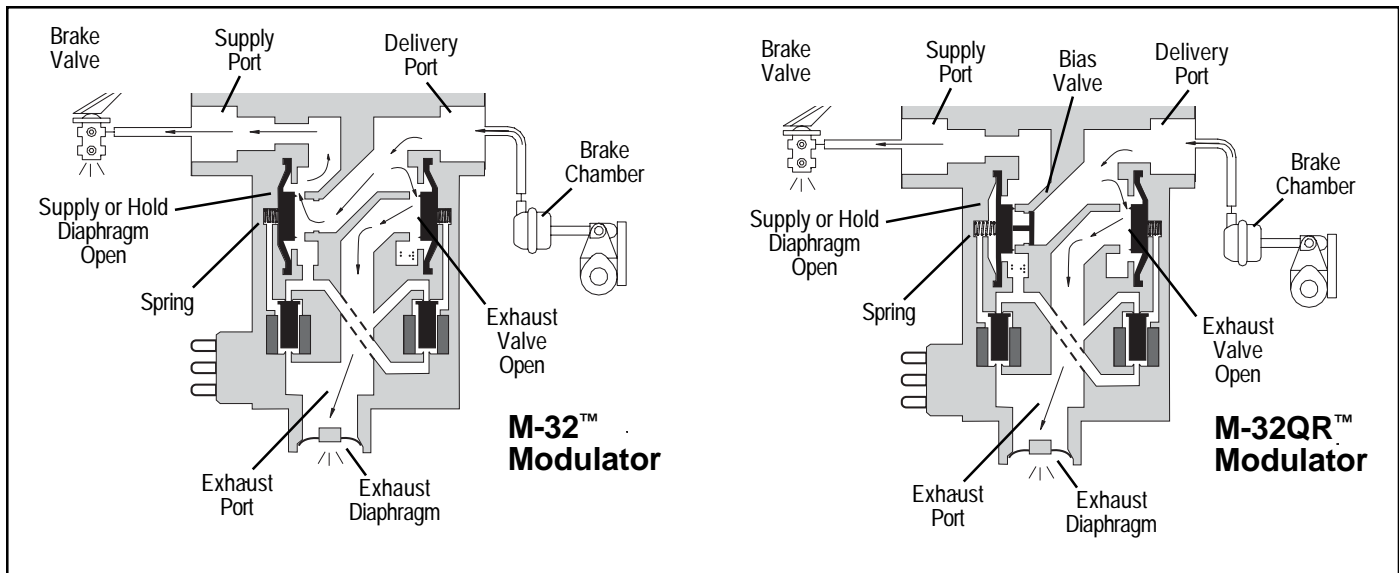

FIGURE 7: M-32™ AND M-32QR™ MODULATORS RAPID NON-ANTILOCK EXHAUST OF SERVICE BRAKES

Rapid Exhaust (Figure 7) - The Rapid Exhaust operation described in the following text occurs when the modulator is controlling service chamber(s). During a rapid brake release the quick release modulator will exhaust air differently to a “slow” brake release.

An example of this would be the case if the driver made a severe brake application then lifted his foot from the foot valve. During a rapid brake release, the air previously delivered to the brake chamber is vented through the M-32™ modulators as follows:

For the M-32QR™ Modulator: The bias valve moves to its closed position, closing the air return route to the brake valve’s exhaust. Air pressure against the exhaust valve within the M-32™ modulator overcomes the spring force and allows air to exhaust through the M-32QR™ modulator exhaust port. Residual air pressure between the bias valve and the brake pedal flows back to the brake valve exhaust.

For the M-32™ Modulator: As in the “slow” brake release, air pressure travels back to the brake valve’s exhaust, but also the air pressure against the exhaust valve within the M-32™ modulator overcomes the spring force and allows air to exhaust through the M-32™ modulator exhaust port.

ANTILOCK OPERATION

GENERAL

If a service brake application is made and the antilock system detects an impending wheel lockup, the antilock controller will make a controlled brake application using the modulator.

In order to control the brake application, the coils of the two solenoid valves contained in the modulator are energized or de-energized in a preprogrammed sequence by the antilock controller. When a solenoid coil is energized, and depending whether the exhaust or hold solenoid is energized, it either

opens or closes, thereby causing the exhaust or reapplication of air pressure to the brake actuator. The solenoids in the modulator are controlled independently by the antilock controller (ECU).

An experienced driver (of a vehicle without ABS) who encounters wheel lock-up may sometimes “pump the brakes” in order to attempt to prevent wheel lock-up and maintain vehicle control. In the case of an ABS braking system, the driver does not need to “pump the brakes” since the antilock controller is able to apply and release the brakes using the modulators, with far greater speed and accuracy. Depending on the number of modulators used, some systems are able to apply braking power to wheels independently (see page 2).

ANTILOCK EXHAUST (Figure 8)

When wheel lock is detected or imminent, the antilock controller energizes the supply and exhaust solenoids in the modulator.

Energizing the supply solenoid allows application air to flow to the control side of the supply diaphragm. Air pressure acting on the supply diaphragm, along with the spring force, enables the diaphragm to prevent further delivery of air to the brake chamber.

Energizing the exhaust solenoid shuts off the air normally applied to the control side of the exhaust diaphragm to keep it closed. Air pressure acting on the exhaust diaphragm, overcomes the spring force, and allows air to exhaust through the exhaust port.

ANTILOCK HOLD MODE (Figure 9)

The antilock controller will place the modulator in the Hold position when it senses that the correct wheel speed (braking force) has been attained. The antilock controller will also

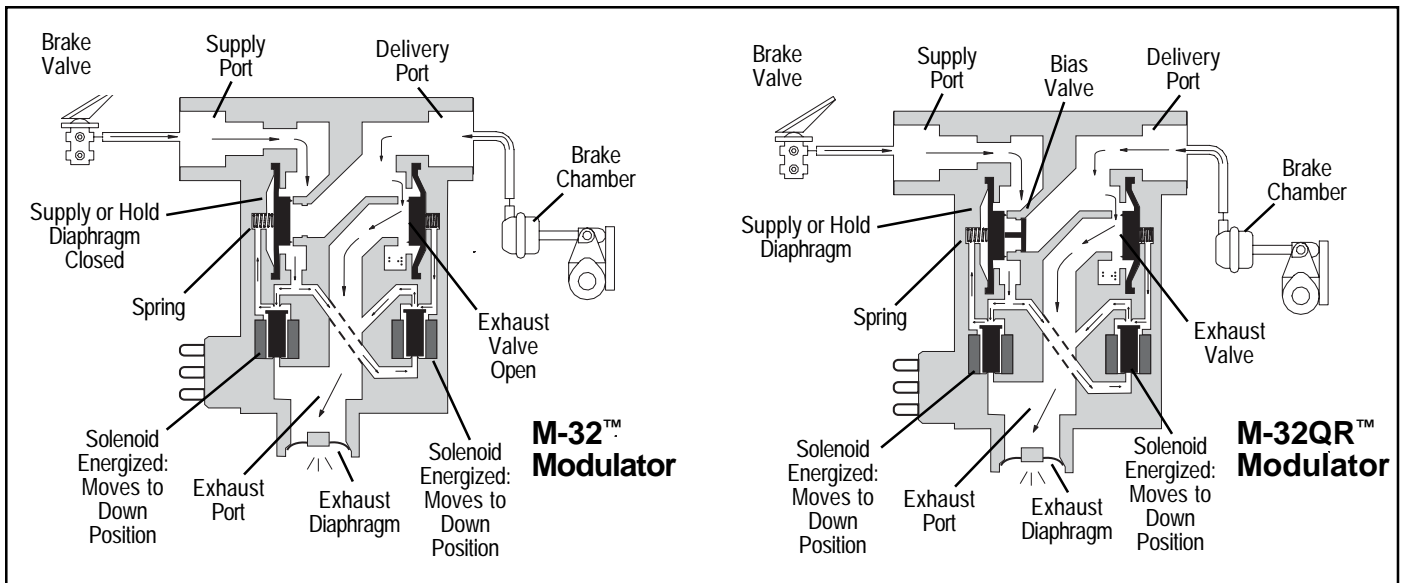

FIGURE 8: M-32™ MODULATOR ANTILOCK EXHAUST OF BRAKES

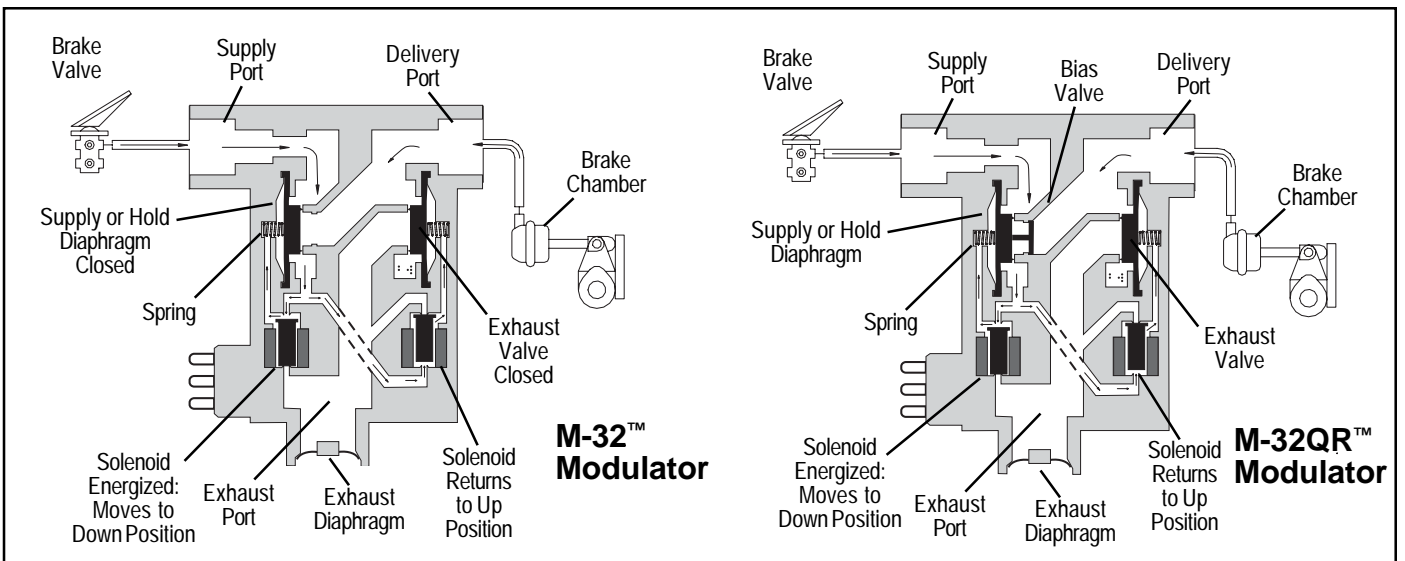

FIGURE 9: M-32™ AND M-32QR™ MODULATORS ANTILOCK APPLICATION HELD POSITION

place the modulator in the hold position, prior to entering the reapply mode, when it detects recovery from a locked wheel condition. In this mode of operation, the modulator supply/hold solenoid remains energized while the exhaust solenoid returns to its normal position. The exhaust solenoid allows application air to flow to the control side of the exhaust diaphragm, which then seals the exhaust passage. With the exhaust diaphragm seated, further exhaust of brake chamber air pressure is prevented. Because the supply solenoid remains energized, the supply diaphragm remains seated, thus preventing application air from flowing to the delivery port and out to the brake chamber. The modulator can enter both the antilock exhaust or reapply mode from the antilock hold mode depending on the needs of the antilock controller.

ANTILOCK “REAPPLY” MODE

If the antilock controller senses that wheel speed has increased sufficiently enough to allow re-application of braking pressure, without further wheel lock-up, it de-energizes the supply solenoid. With both solenoids de-energized, the modulator re-applies air to the brakes in the same manner it did during a non-antilock event.

PREVENTIVE MAINTENANCE

GENERAL

Perform the tests and inspections presented at the prescribed intervals. If the modulator fails to function as described, or leakage is excessive, it should be replaced with a new Bendix unit, available at any authorized parts outlet.

EVERY MONTH, 10,000 MILES OR 350 OPERATING HOURS

1. Remove any accumulated contaminants and visually inspect the exterior for excessive corrosion and physical damage.
2. Inspect all air lines and wire harnesses connected to the modulator for signs of wear or physical damage. Replace as necessary.
3. Test air line fittings for leakage and tighten or replace as necessary.
4. Perform the ROUTINE OPERATION AND LEAKAGE TESTING described in this manual.

OPERATION & LEAKAGE TESTS

LEAKAGE TEST

1. Park the vehicle on a level surface and block or chock the wheels. Release the parking brakes and build the air system to full pressure.
2. Turn the engine OFF and make 4 or 5 brake applications and note that the service brakes apply and release promptly.
3. Build system pressure to governor cut-out and turn the engine OFF.
4. After determining the pressure loss with the brakes released (2 PSI/minute allowed), make and hold a full service brake application. Allow the pressure to stabilize for one minute.
5. Begin timing pressure loss for two minutes while watching the dash gauges for a pressure drop. The leakage rate for the service reservoirs should not exceed 3 PSI/minute.
6. If either circuit exceeds the recommended two PSI/minute, apply soap solution to the exhaust port of the modulator and any other components in the respective circuit.
7. The leakage at the exhaust port of most Bendix components, including M-32™ modulators, should not exceed a one-inch bubble in three seconds. If leakage at the modulator is determined to exceed the maximum limits, replace the modulator.

OPERATION TEST

To properly test the function of the modulator will require two (2) service technicians.

1. Park the vehicle on a level surface and block or chock the wheels. Release the parking brakes and build the air system to governor cut out.
2. Turn the engine ignition key to the OFF position then make and hold a full brake application.
3. With the brake application held and one (1) service technician posted at one (1) of the modulators, turn the vehicle ignition key to the ON position. ONE OR TWO SHORT bursts of air pressure should be noted at the modulator exhaust. Repeat the test for each modulator on the vehicle. If at least a single burst of exhaust is not noted or the exhaust of air is prolonged and not short, sharp and well defined, perform the Electrical Tests.

ELECTRICAL TESTS

1. Before testing the solenoid assembly of a suspect modulator, its location on the vehicle should be confirmed using the Trouble Shooting or Start Up procedure for the specific antilock controller in use. (See the Service Data Sheet for the antilock controller for this procedure.)
2. Proceed to the modulator in question and inspect its wiring connector. Disconnect the connector and test the resistance between the pins ON THE MODULATOR. Refer to Figures 10 and 11.
 - A. HOLD TO SOURCE (41-42): Read 4.9 to 5.5 Ohms.
 - B. EXHAUST TO SOURCE (43-41): Read 4.9 to 5.5 Ohms.
 - C. EXHAUST TO HOLD (43-42): Read 9.8 to 11.0 Ohms.
 - D. Individually test the resistance of each pin to vehicle ground and note there is NO CONTINUITY.

If the resistance readings are as shown, the wire harness leading to the modulator may require repair or replacement. Before attempting repair or replacement of the wire harness, refer to the test procedures specified for the antilock controller in use for possible further testing that may be required to substantiate the wire harness problem. If the resistance values are NOT AS STATED, replace the modulator.

WARNING! PLEASE READ AND FOLLOW THESE INSTRUCTIONS TO AVOID PERSONAL INJURY OR DEATH:

When working on or around a vehicle, the following general precautions should be observed at all times.

1. **Park the vehicle on a level surface, apply the parking brakes, and always block the wheels. Always wear safety glasses.**

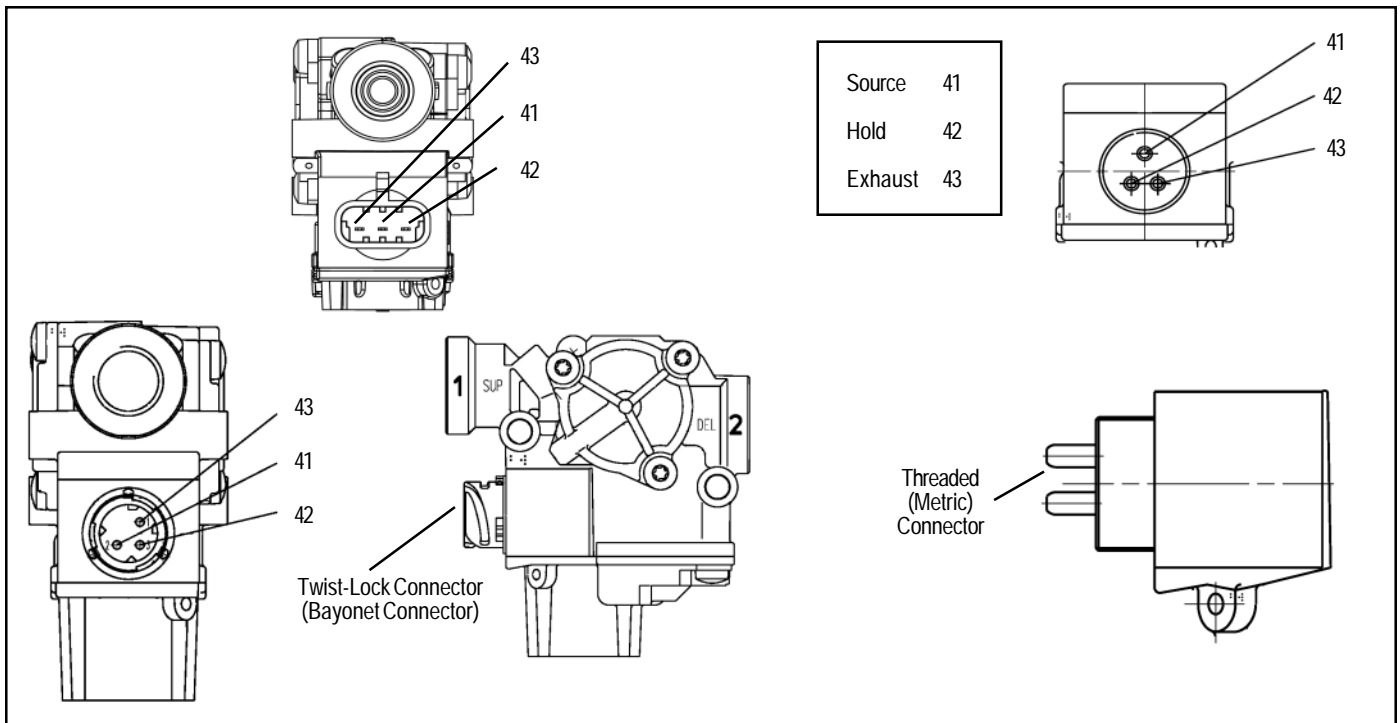

FIGURE 10: M-32™ AND M-32QR™ MODULATORS CONNECTOR VIEWS

2. Stop the engine and remove ignition key when working under or around the vehicle. When working in the engine compartment, the engine should be shut off and the ignition key should be removed. Where circumstances require that the engine be in operation, **EXTREME CAUTION** should be used to prevent personal injury resulting from contact with moving, rotating, leaking, heated or electrically charged components.
3. Do not attempt to install, remove, disassemble or assemble a component until you have read and thoroughly understand the recommended procedures. Use only the proper tools and observe all precautions pertaining to use of those tools.
4. If the work is being performed on the vehicle's air brake system, or any auxiliary pressurized air systems, make certain to drain the air pressure from all reservoirs before beginning **ANY** work on the vehicle. If the vehicle is equipped with an AD-IS™ air dryer system or a dryer reservoir module, be sure to drain the purge reservoir.
5. Following the vehicle manufacturer's recommended procedures, deactivate the electrical system in a manner that safely removes all electrical power from the vehicle.
6. Never exceed manufacturer's recommended pressures.
7. Never connect or disconnect a hose or line containing pressure; it may whip. Never remove a component or plug unless you are certain all system pressure has been depleted.
8. Use only genuine Bendix® replacement parts, components and kits. Replacement hardware, tubing, hose, fittings, etc. must be of equivalent size, type and strength as original equipment and be designed specifically for such applications and systems.
9. Components with stripped threads or damaged parts should be replaced rather than repaired. Do not attempt repairs requiring machining or welding unless specifically stated and approved by the vehicle and component manufacturer.
10. Prior to returning the vehicle to service, make certain all components and systems are restored to their proper operating condition.
11. For vehicles with Antilock Traction Control (ATC), the ATC function must be disabled (ATC indicator lamp should be ON) prior to performing any vehicle maintenance where one or more wheels on a drive axle are lifted off the ground and moving.

MODULATOR REMOVAL

1. Locate the modulator that will be replaced and clean the exterior.
2. Identify and mark or label all air lines and their respective connections on the valve to facilitate ease of installation.
3. Disconnect both air lines and the electrical connector.
4. Remove the modulator from the vehicle.
5. Remove all air line fittings and plugs. **These fittings will be re-used in the replacement modulator.**

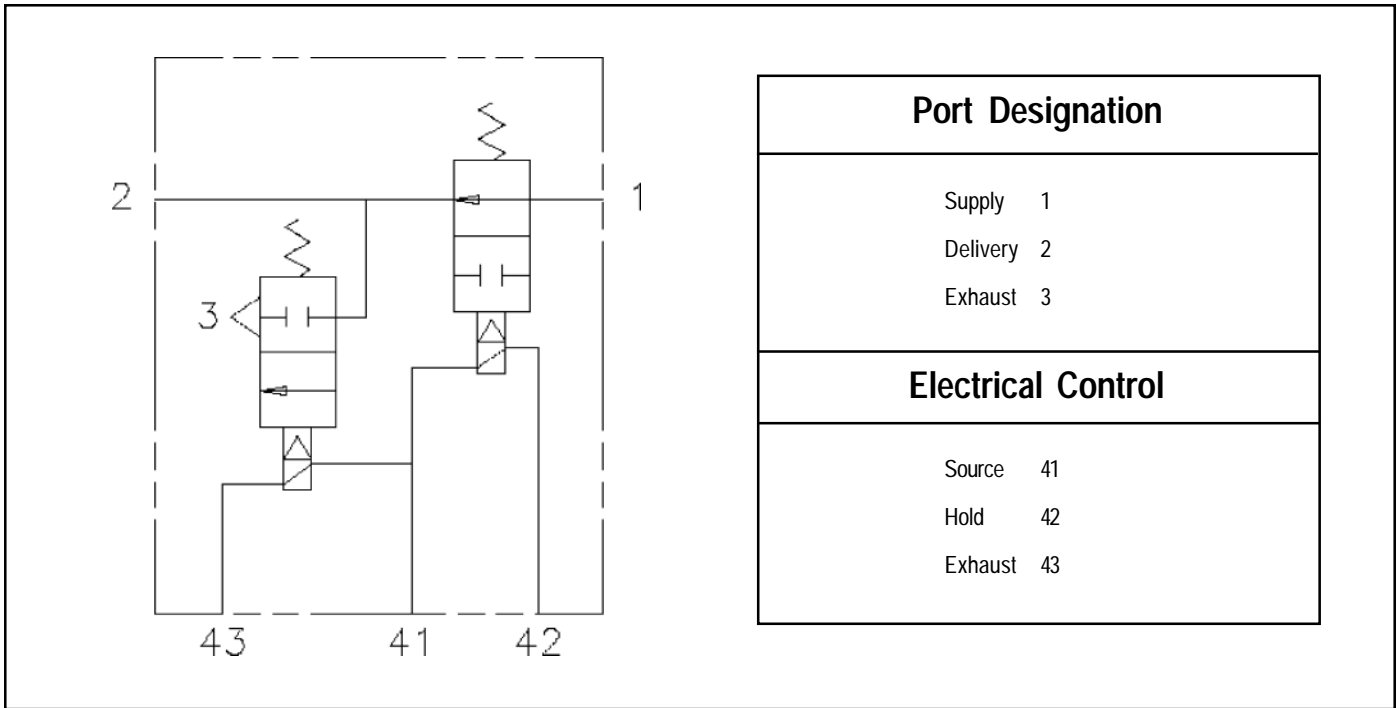

FIGURE 11: M-32™ AND M-32QR™ MODULATORS DIN SYMBOL

MODULATOR INSTALLATION

1. Install all air line fittings and plugs, making certain thread sealing material does not enter the valve.
2. Install the assembled valve on the vehicle.
3. Reconnect both air lines to the valve using the identification made during VALVE REMOVAL step 5.
4. Reconnect the electrical connector to the modulator.
5. After installing the valve, test all air fittings for excessive leakage and tighten as needed.

TECHNICAL INFORMATION

- Porting** 1 Supply Port (from brake, relay or quick release valve) - 1/2" NPT
- 1 Delivery Port (brake actuator) - 1/2" NPT
- Optional:** 1 Push-to-connect for 1/2" tubing
- 2 NPT supply, PTC delivery
- Solenoid Voltage:** 12 Volts DC Nominal, optional 24 Volt available.
- Weight:** 1.7 pounds
- Maximum Operating Pressure:** 150 psi Gauge
- Operating Temperature Range:** -40 to 185 degrees Fahrenheit
- Pressure Differential:** 1 psi maximum (supply to delivery)
- Mounting Hole Sizes:** 0.33" diameter through body

